

In order to choose the best  $f/D$  value for cylinder, I change some parameters of the feed made by institute 54. The different  $f/D$  values of cylinder is as follows:

**(1)  $f/D=0.265$**

The reflector focal length on diameter ratio ( $f/D$ ) is 0.265 which corresponds to a subtended half-angle( $\theta_{ha}$ ) of 86.6 degrees calculated from Equation 1.1. The subtended half-angle refers to an angle subtended by the reflector edges at the focal point and is illustrated in Figure1.1.

$$\frac{f}{D} = \frac{1}{4} \cot \frac{\theta_{ha}}{2} \tag{1.1}$$

$$\theta_{ha} = 2 \tan^{-1} \left[ \frac{1}{4(f / D)} \right] \tag{1.2}$$

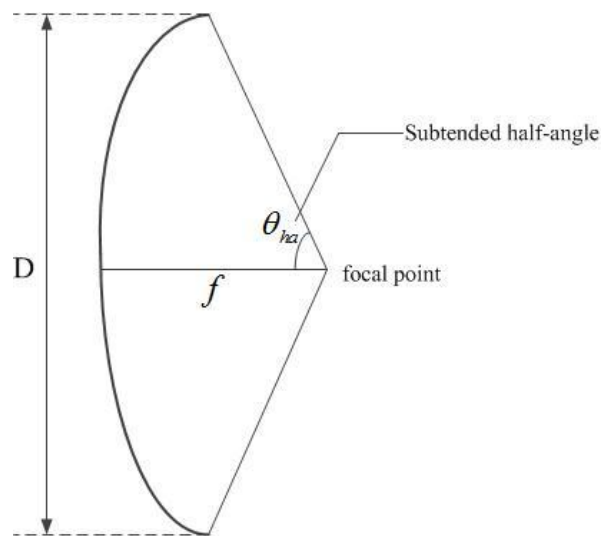

Figure1.1 Cross-sectional view of the cylinder in the transverse plane

When the radius of reflection cavity is 100mm as depicted in Figure1.2, we can get a subtended half-angle( $\theta_{ha}$ ) of 86.6 degrees for cylinder.

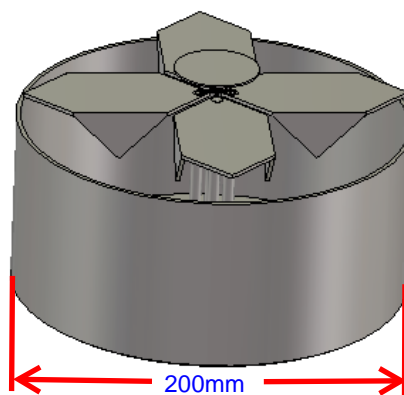

Figure1.2 The feed for cylinder when radius of cavity is 100mm

The cylinder has an aperture length of 40m, diameter(D), of 15m and focal length(f), of 4m in CST software. Figure1.3 show the farfield pattern for cylinder.

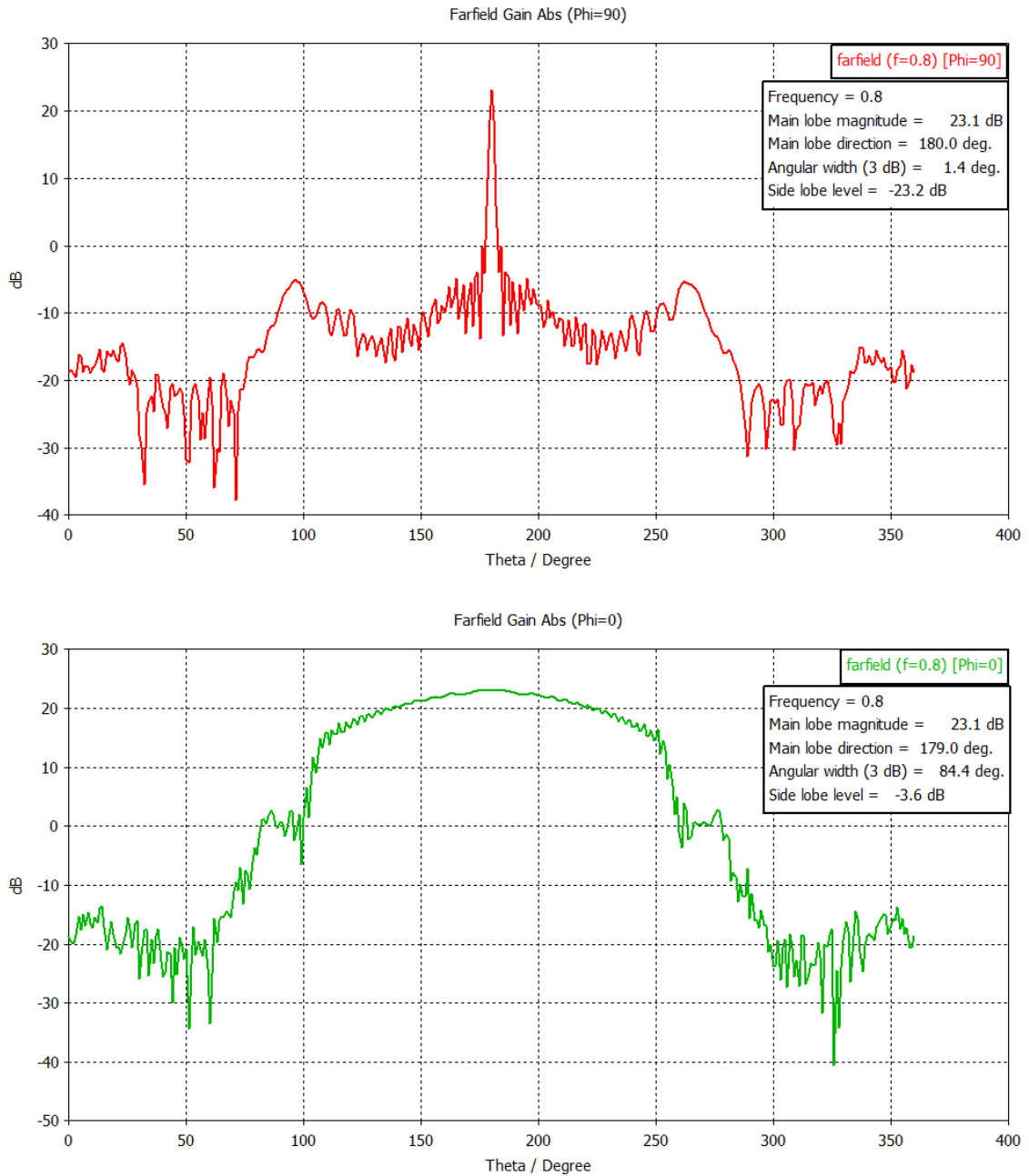

Figure1.3 The farfield pattern for cylinder

## (2) $f/D=0.32$

The reflector focal length on diameter ratio ( $f/D$ ) is 0.32 which corresponds to a subtended half-angle ( $\theta_{ha}$ ) of 70 degrees calculated from Equation 1.1.

When the height of reflection cavity is 90mm as depicted in Figure2.1, we can get a subtended half-angle ( $\theta_{ha}$ ) of 70 degrees for cylinder.

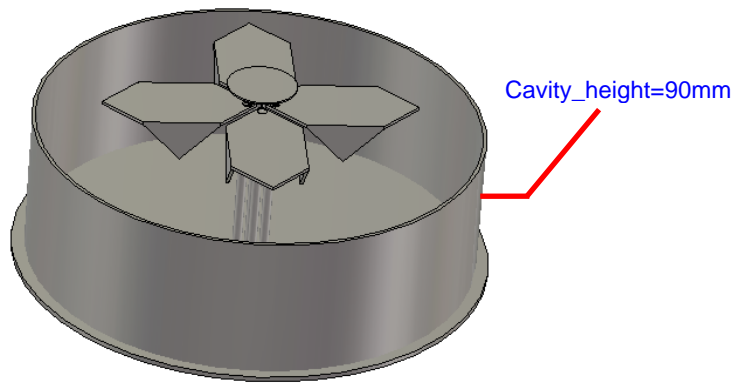

Figure2.1 The feed for cylinder when height of cavity is 90mm

The cylinder has an aperture length of 40m, diameter(D), of 15m and focal length(f), of 4.8m in CST software. Figure2.2 show the farfield pattern for cylinder.

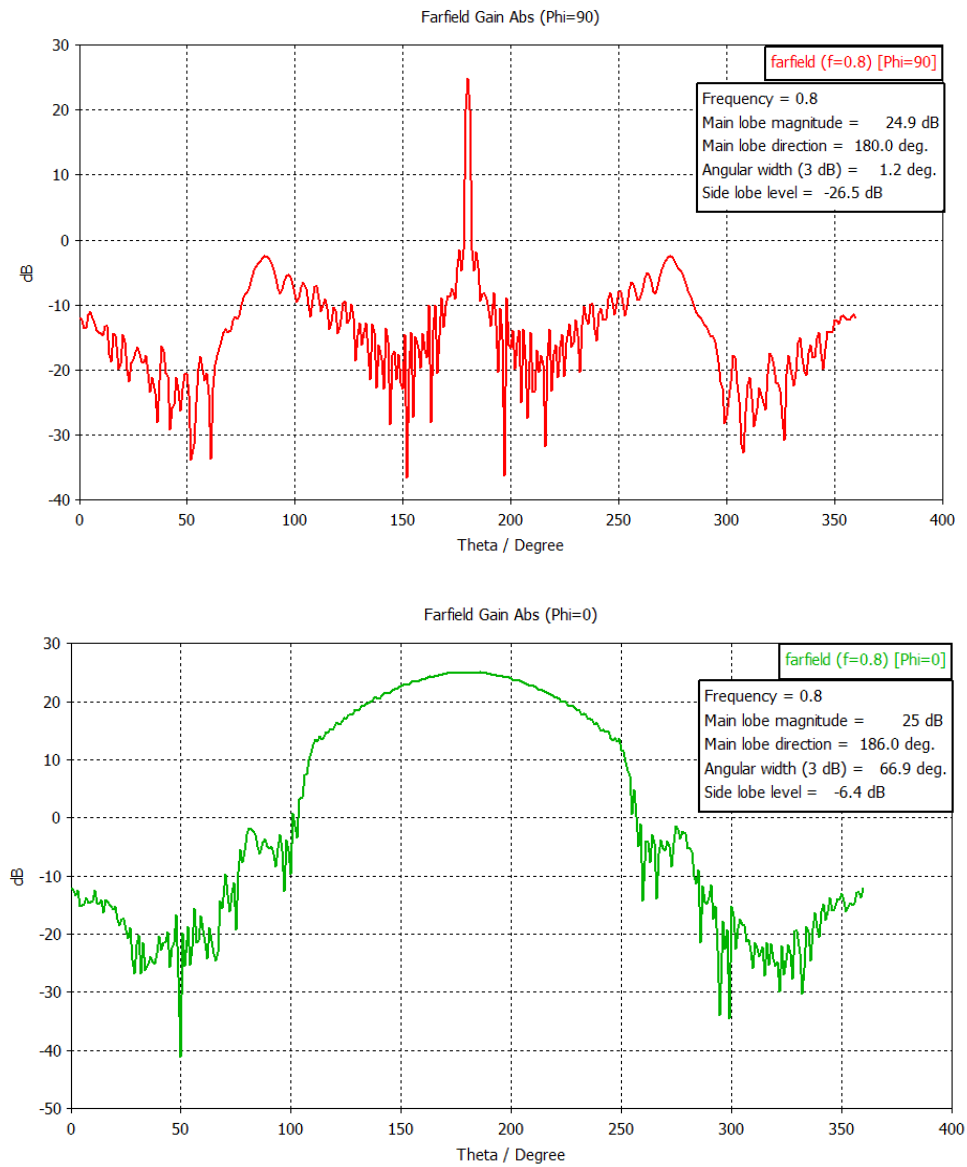

Figure2.2 The farfield pattern for cylinder

### (3) $f/D=0.357$

The reflector focal length on diameter ratio ( $f/D$ ) is 0.357 which corresponds to a subtended half-angle ( $\theta_{ha}$ ) of 74 degrees calculated from Equation 1.1.

When the height of reflection cavity is 70mm as depicted in Figure3.1, we can get a subtended half-angle ( $\theta_{ha}$ ) of 74 degrees for cylinder.

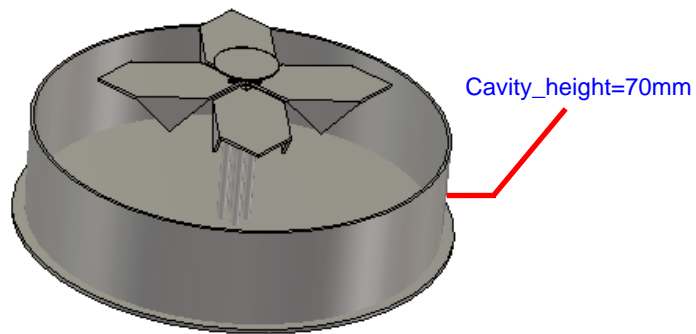
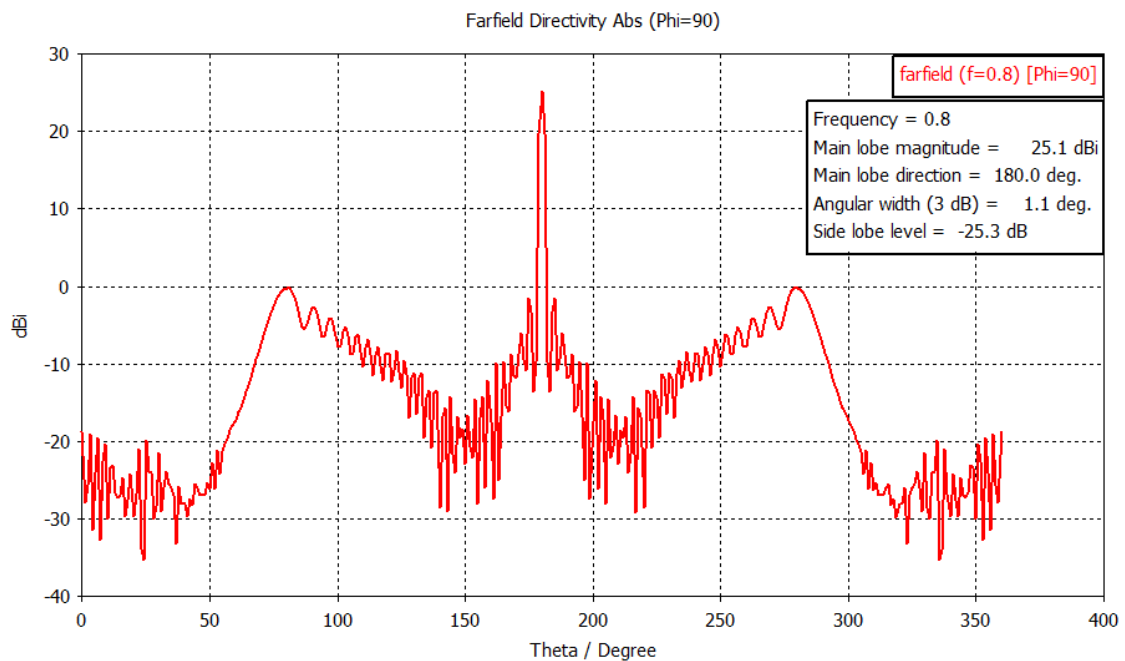

Figure3.1 The feed for cylinder when height of cavity is 70mm

The cylinder has an aperture length of 40m, diameter(D), of 15m and focal length(f), of 5.4m in CST software. Figure3.2 show the farfield pattern for cylinder.



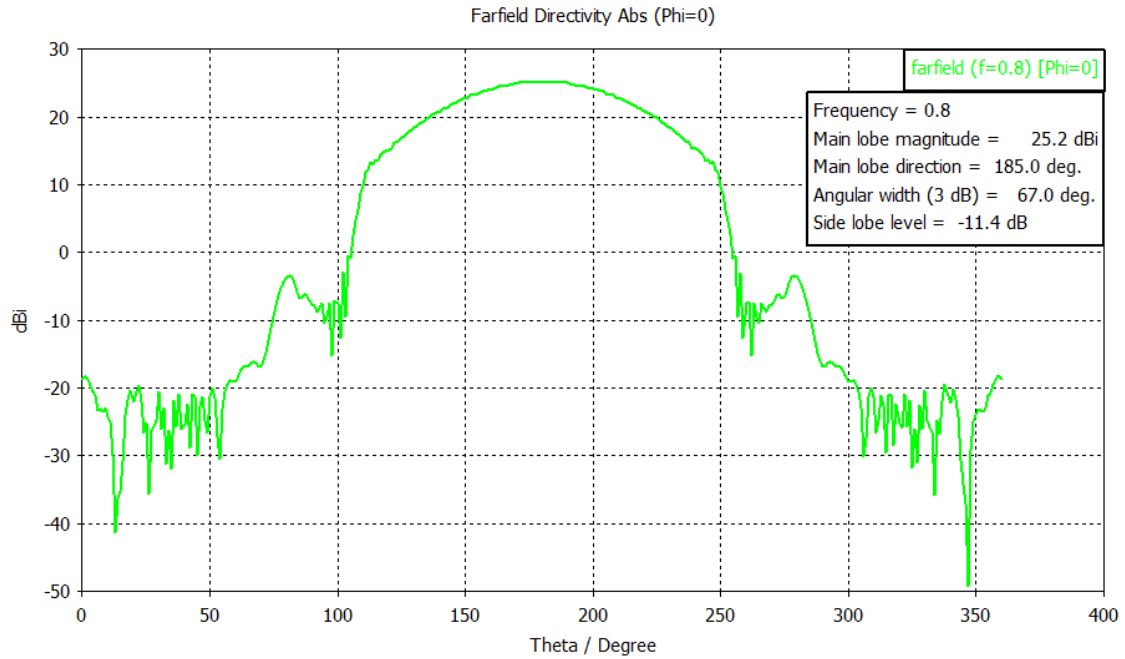

Figure3.2 The farfield pattern for cylinder

#### (4) $f/D=0.38$

The reflector focal length on diameter ratio ( $f/D$ ) is 0.38 which corresponds to a subtended half-angle ( $\theta_{ha}$ ) of 66 degrees calculated from Equation 1.1.

When the height of reflection cavity is 40mm as depicted in Figure4.1, we can get a subtended half-angle ( $\theta_{ha}$ ) of 66 degrees for cylinder.

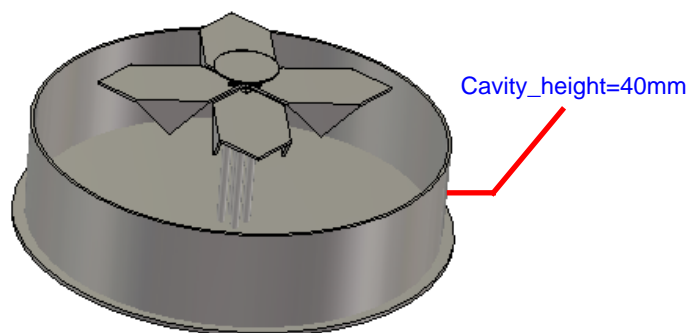

Figure4.1 The feed for cylinder when height of cavity is 40mm

The cylinder has an aperture length of 40m, diameter( $D$ ), of 15m and focal length( $f$ ), of 5.8m in CST software. Figure4.2 show the farfield pattern for cylinder.

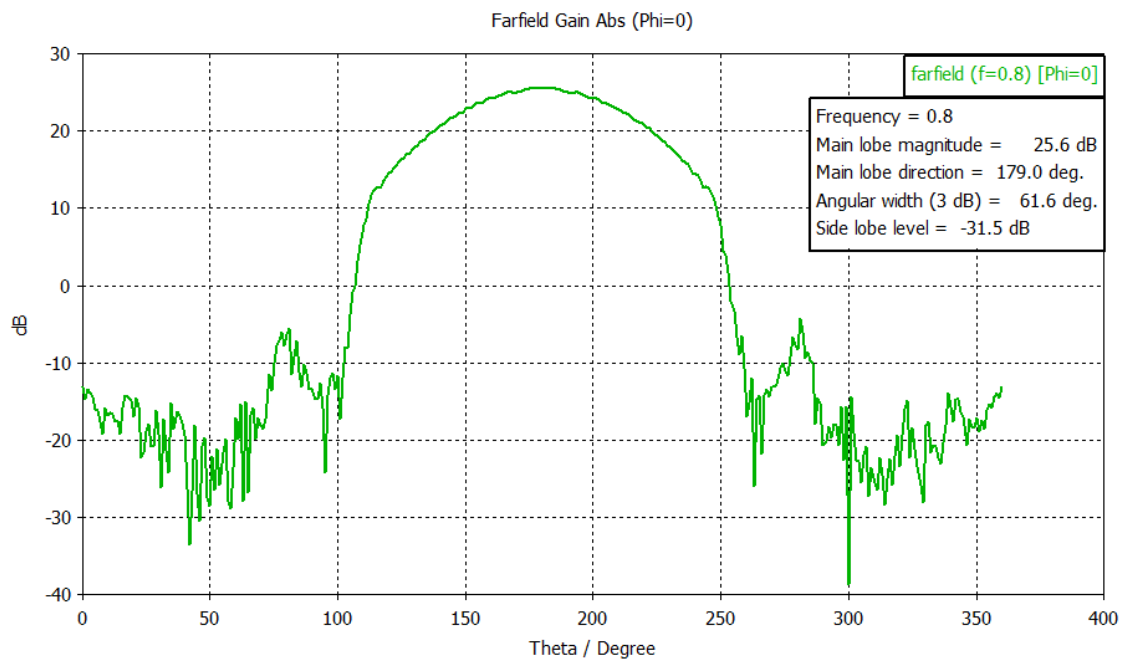
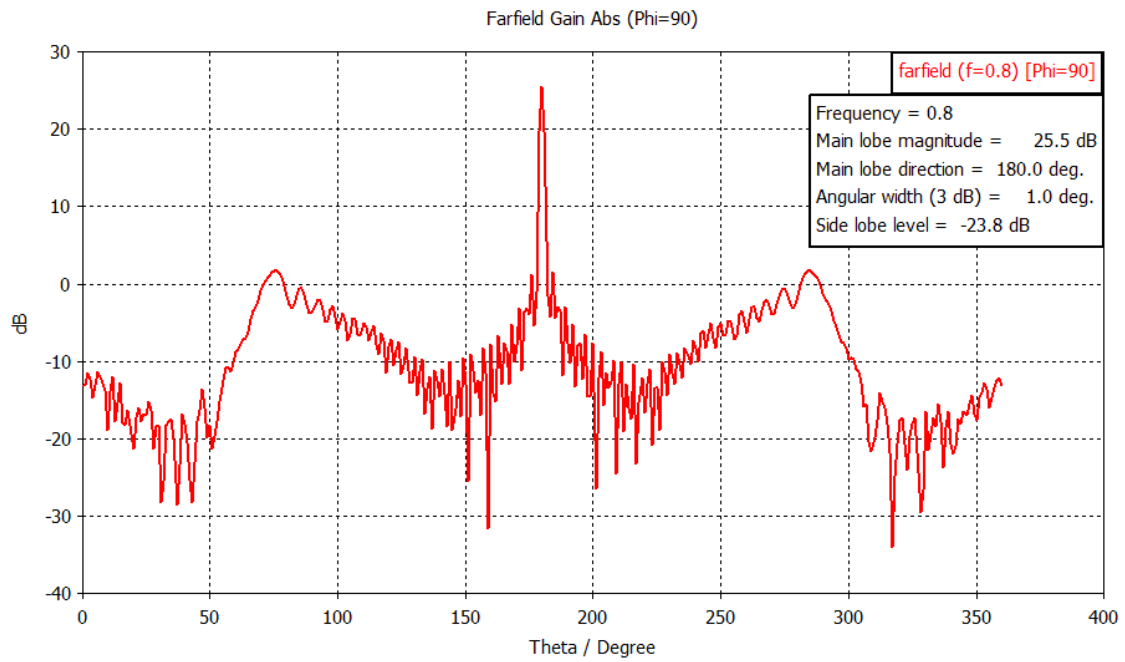
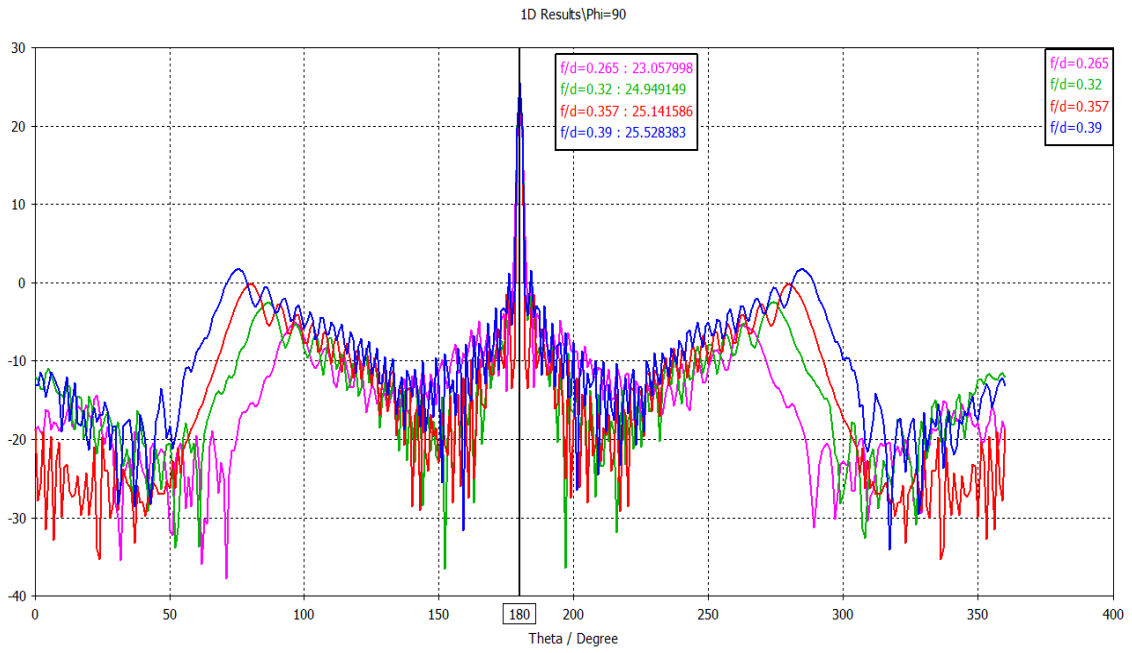
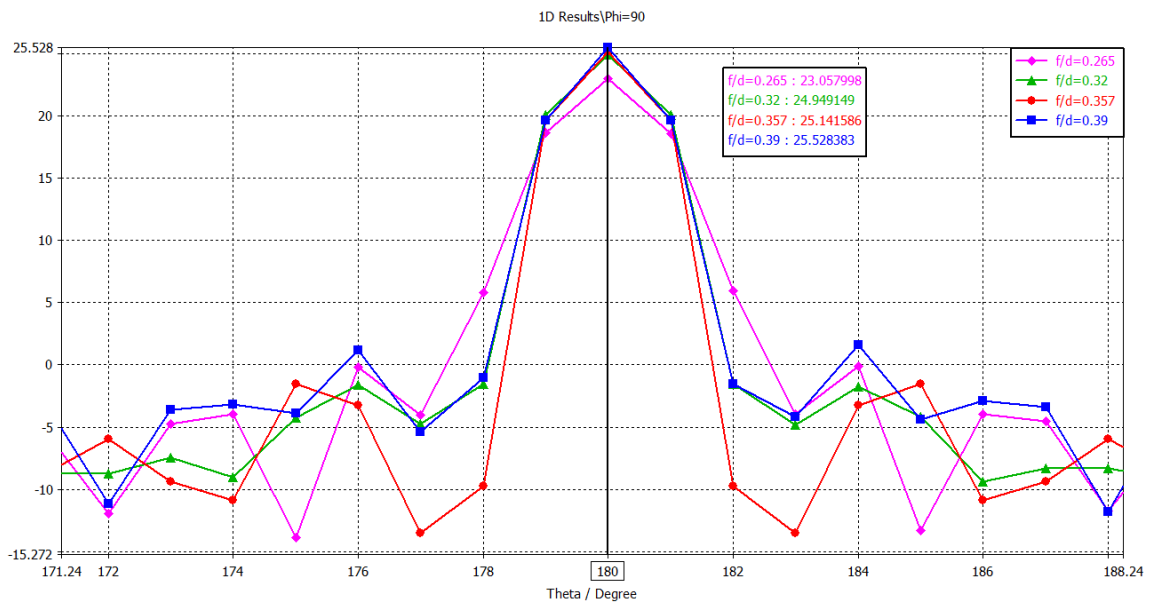

Figure4.2 The farfield pattern for cylinder

**(5) Comparing the different f/D values of cylinder**



(a) Common view



(b) Enlarged view

Figure5.1 Theta scan(perpendicular to antenna length) for cylinder in different  $f/D$  values

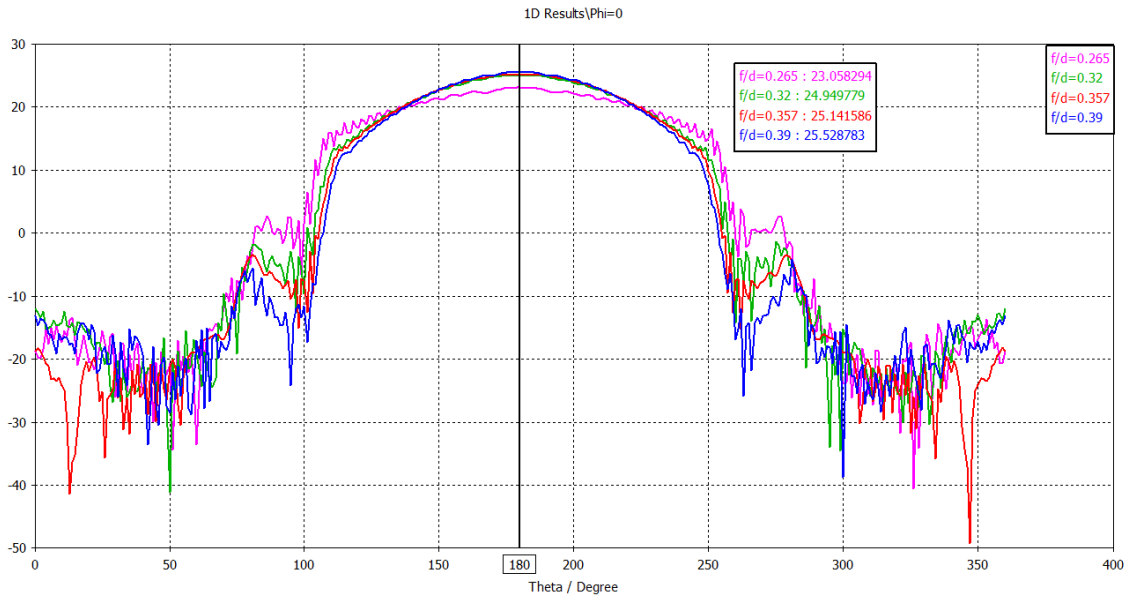

(a) Common view

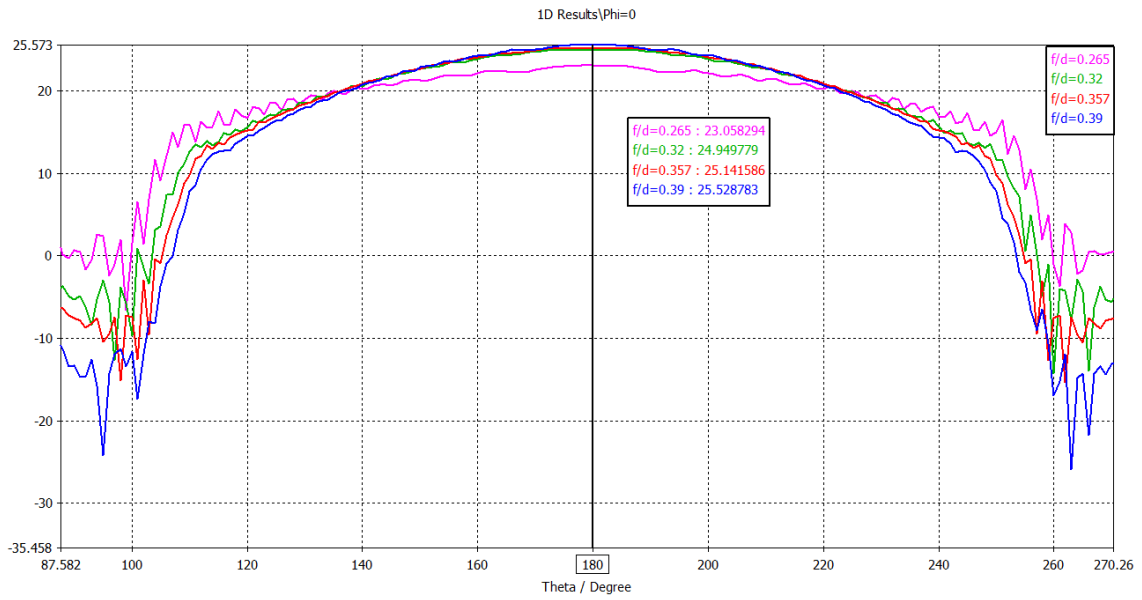

(b) Enlarged view

Figure 5.2 Phi scan (parallel to antenna length) for cylinder in different f/D values