

# Progress on the study of Smith-Purcell radiation as bunch length diagnostic

Nicolas Delerue

LAL (CNRS and Université de Paris-Sud)



*Work supported by seed funding from Université Paris-Sud, program « Attractivité »  
and by the ANR under contract ANR-12-JS05-0003-01.*

# Smith-Purcell radiation

- Discovered experimentally in 1953 by Smith and Purcell.
- Electrons passing near a grating induce the emission of (visible) radiation.
- *Radiation is dispersed spectrally.*
- S.J. Smith and E.M. Purcell, Phys. Rev. **92**, pg. 1069, (1953)
- 300 keV electrons to emit in the visible wavelengths ( $d = 1.67 \mu\text{m}$ )
- Theta is the azimuthal angle.

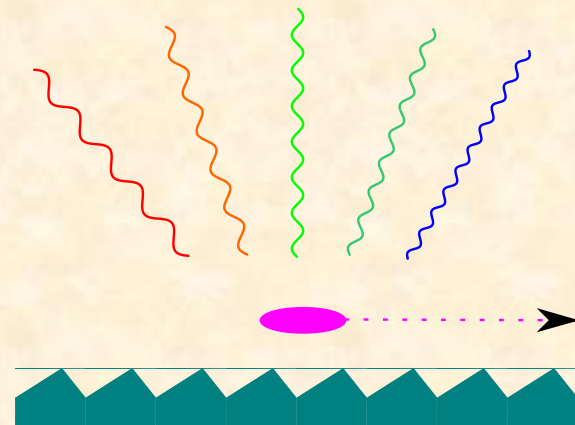
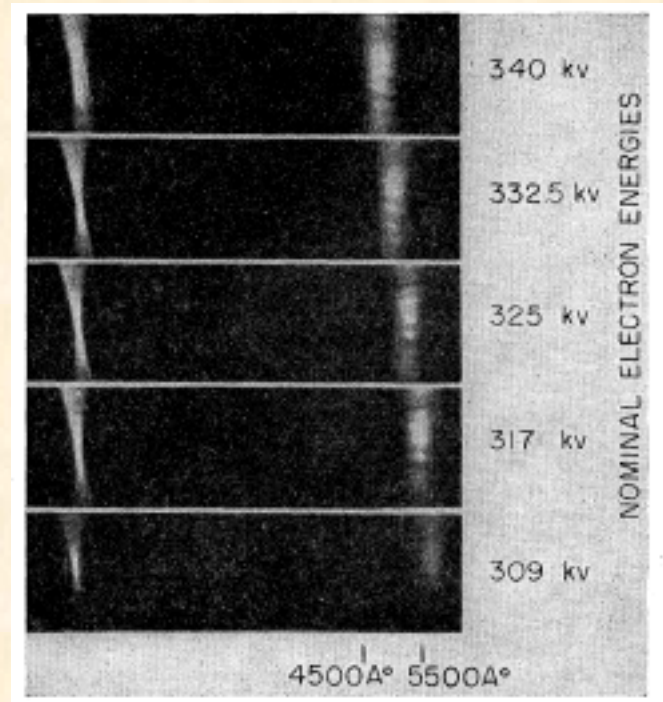

$$\lambda = \frac{\ell}{n} \left( \frac{1}{\beta} - \cos\theta \right)$$

# SP radiation and bunch profile

- The intensity of the radiation depends on the distance between the bunch and the grating.
- It depends also on the pitch of the grating.
- For relativistic electrons the beam energy is not very important.

$$\left( \frac{dI}{d\Omega} \right)_{\text{sp}} = 2\pi q^2 \frac{Z}{\ell^2} \frac{n^2 \beta^3}{(1 - \beta \cos \theta)^3} R^2 \exp\left( -\frac{2x_0}{\lambda_e} \right)$$

$$\lambda_e = \frac{\lambda}{2\pi} \frac{\beta\gamma}{\sqrt{1 + \beta^2 \gamma^2 \sin^2 \theta \sin^2 \phi}}$$

# Coherent SP radiation

- Like many other radiative phenomena in EM, SP radiation can also be coherent at wavelength sufficiently longer than the bunch length.
- In both interpretation SP radiation depends on the shape of the electron bunch and the wavelength of the photons emitted encodes the Fourier transform of the electron bunch longitudinal profile.
- This means that for sufficiently short bunches the signal intensity is proportional to the square of the beam charge.

$$\left( \frac{dI}{d\Omega d\omega} \right)_{N_e} (\Omega, \omega) = \left( \frac{dI}{d\Omega d\omega} \right)_{sp} (\Omega, \omega) \cdot [N_e + N_e(N_e - 1) |F(\omega)|^2]$$

# Coherent SPR as a longitudinal profile diagnostic

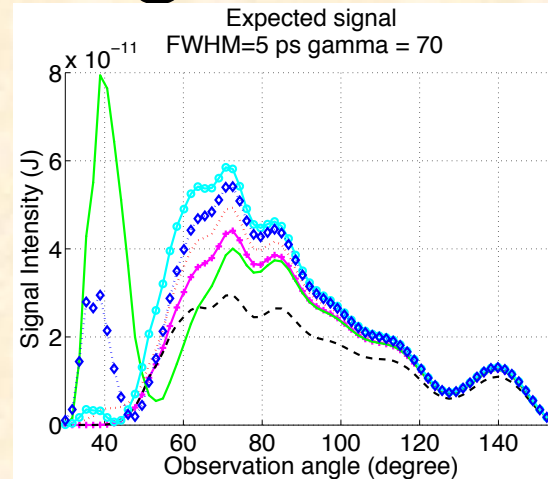
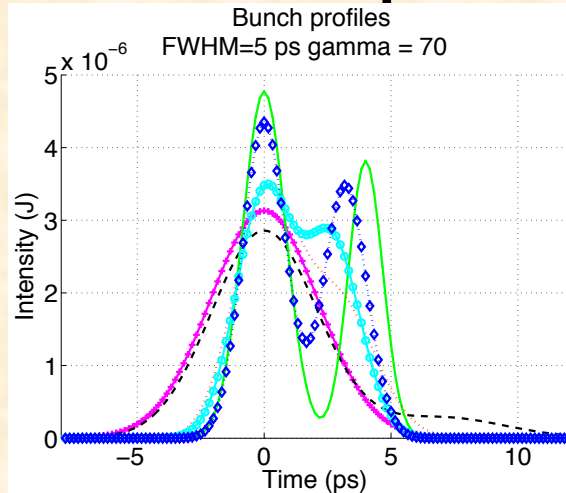

- Because Coherent SPR encodes the Fourier transform of the longitudinal profile, it can be used as a diagnostic.
- Such diagnostic requires a measurement of the SPR spectrum.

$$\left( \frac{dI}{d\Omega d\omega} \right)_{N_e} (\Omega, \omega) = \left( \frac{dI}{d\Omega d\omega} \right)_{sp} (\Omega, \omega) \cdot [N_e + N_e(N_e - 1) |F(\omega)|^2]$$

# Profile recovery

- Once the spectrum has been measured, one can attempt to recover the beam profile.
- To recover the profile we use the square of the Fourier Transform.
- However, the phase information is missing.
- Recovered using Kramers-Kronig or Hilbert relations.
- Work presented at IPAC'15.

$$\phi(\omega) = \frac{2\omega}{\pi} \int_0^{\omega} \frac{\ln [\rho(\omega)/\rho(\omega_0)]}{\omega_0^2 - \omega^2} d\omega$$

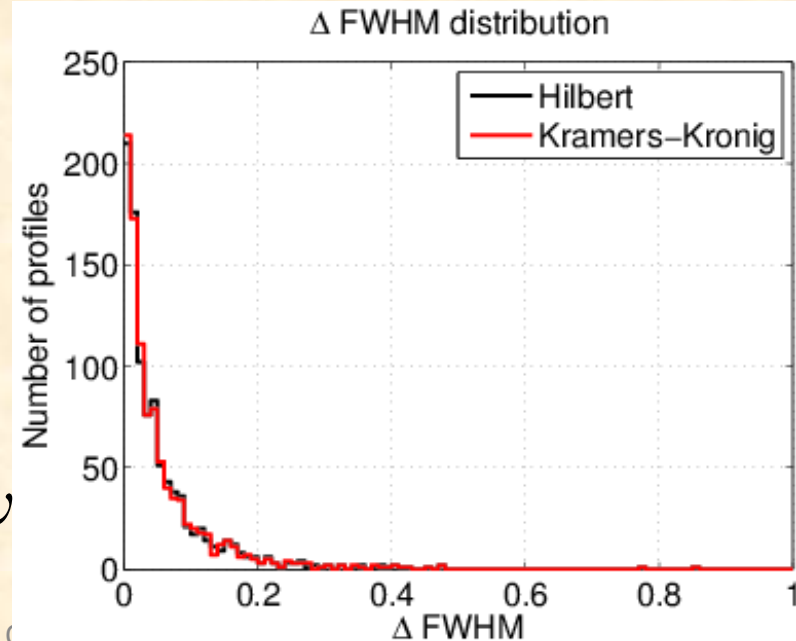
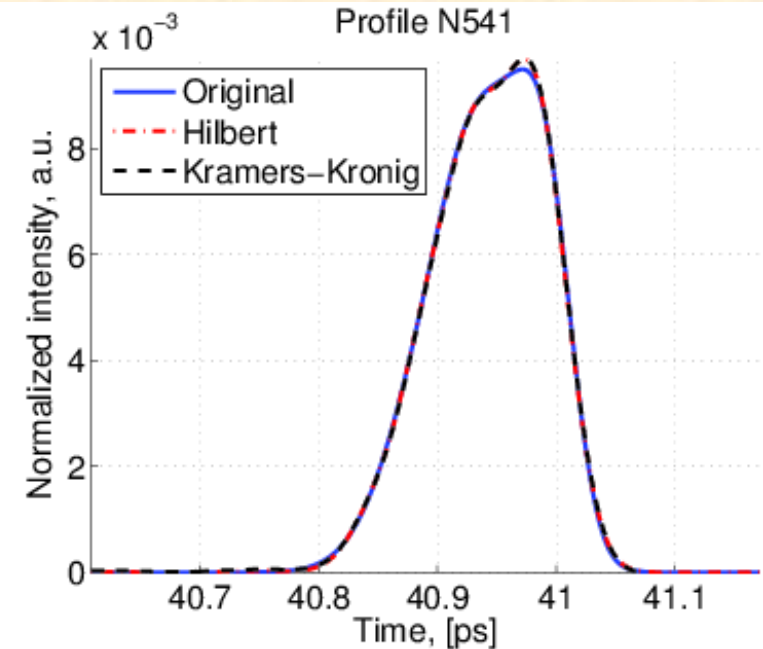



# CSPR as a longitudinal diagnostic: Work so far

- George Doucas from Oxford has been investigating CSPR as a longitudinal diagnostic for several years.
- Initial work on picosecond bunches
  - => Test at FELIX (45MeV) in the Netherlands  
Phys. Rev. ST Accel. Beams 9, 092801 (2006)
  - => Test at End Station A at SLAC (28.5 GeV)  
Phys. Rev. ST Accel. Beams 12, 032803 (2009)
- Extension to the femtoseconds range:  
E-203 Experiment at FACET 2011-2015 (Oxford, LAL, LANL, SLAC,...).
- SPESO at SOLEIL => characterisation of CSPR
- SP at CLIO => New geometry

# E-203 Results

- Paper with profile reconstruction published in 2014.
- Further data taking in 2015 to study the polar distribution of the signal and its polarisation.

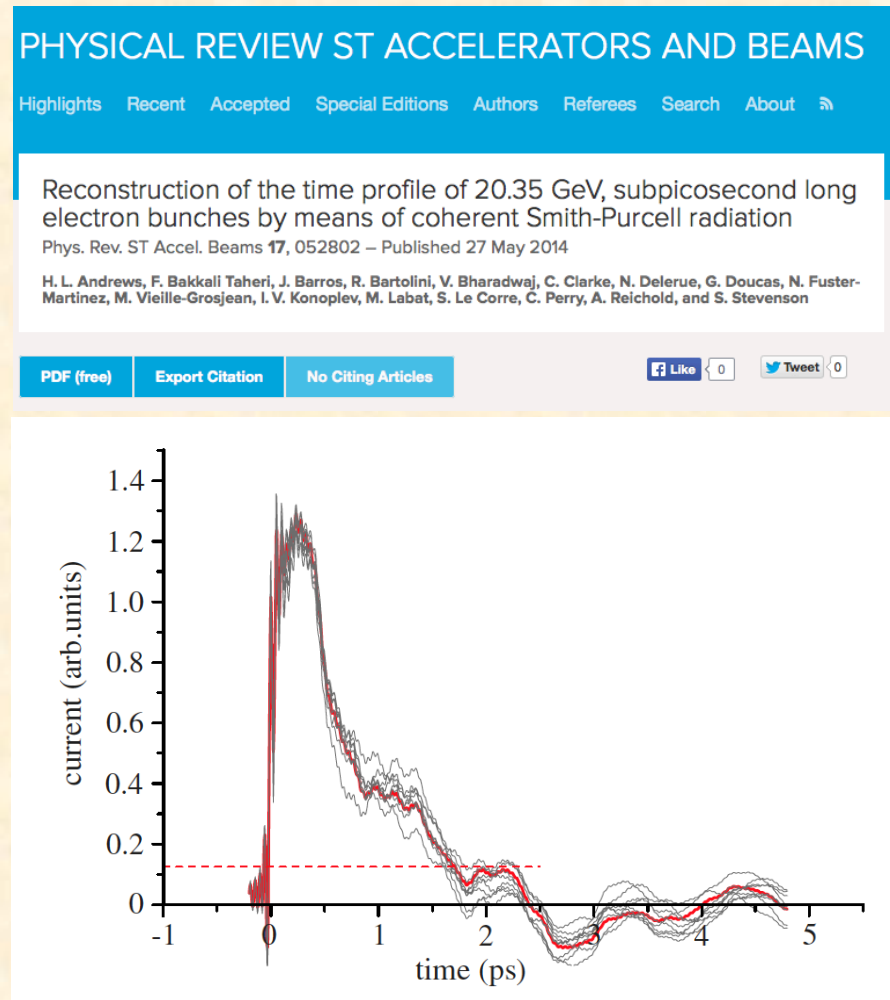



# SPESO

- To overcome the E-203 limitations, a Smith-Purcell test stand has been installed at the end of the SOLEIL Linac (gamma=200).
- A 5D robot can measure the radiation emitted at different position and angles.
- A polarisation measurement system has been added to study the radiation polarisation.

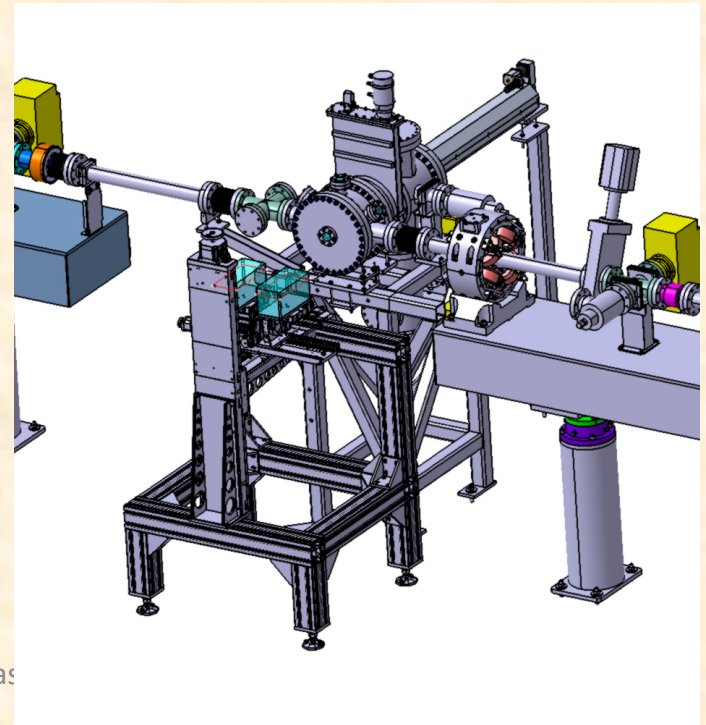
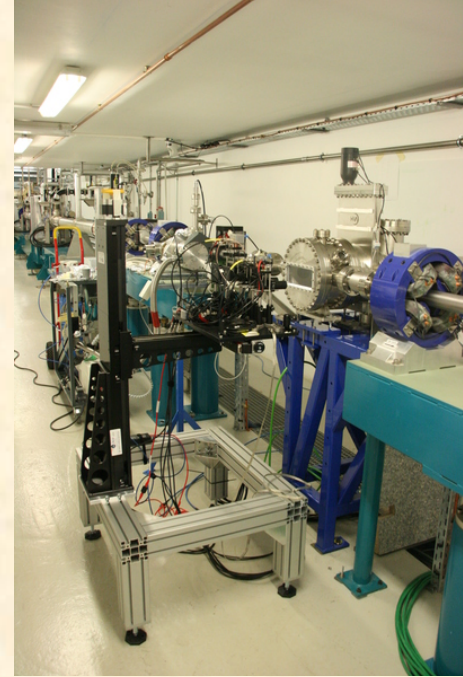

# SPESO:

## polarisation measurements

- Using the polariser installed in summer 2016 we have performed some polarisation measurements.
- The value is not as expected: polarisation is only about 50% when almost 100% was expected...
- However this value is consistent with what was observed at E-203 in 2012. => Is the polarization of SP radiation correctly described by the theory?

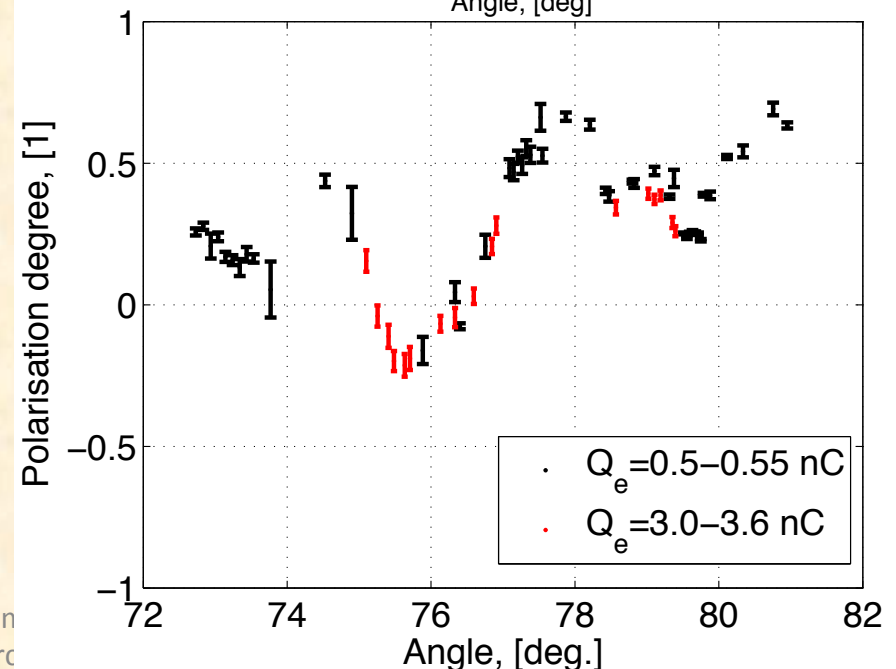
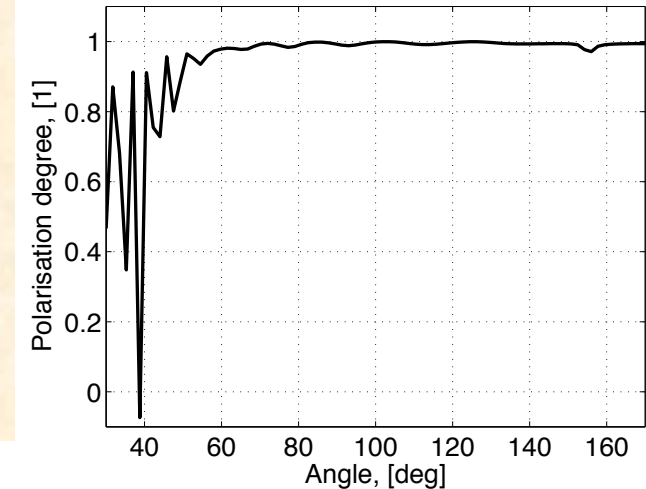

# SP at CLIO

- CLIO is the French Free Electron Laser, located in Orsay (within LAL building).
- Bunch of the order of a few ps.
- Aim of the SP setup: test different geometries than at SPARC.

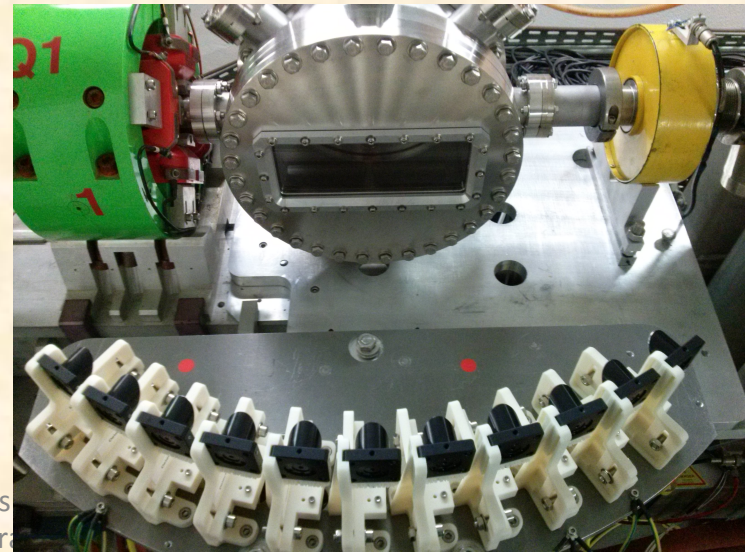
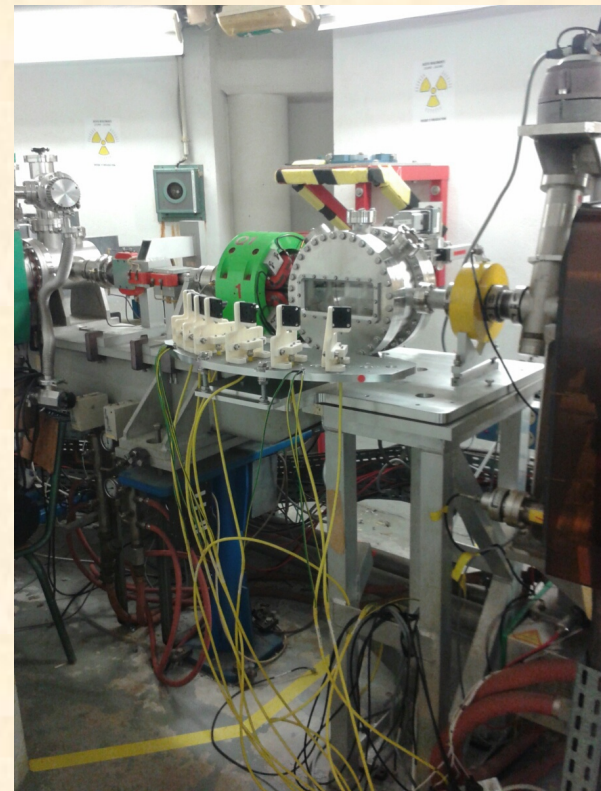



# SP @CLIO: Results (1)

- First results presented at IPAC17.
- Significant progress during the master thesis of Vitalii Khodenych.
- Better understanding of the noise and its rejection.
- Good agreement between signal shape and predictions.

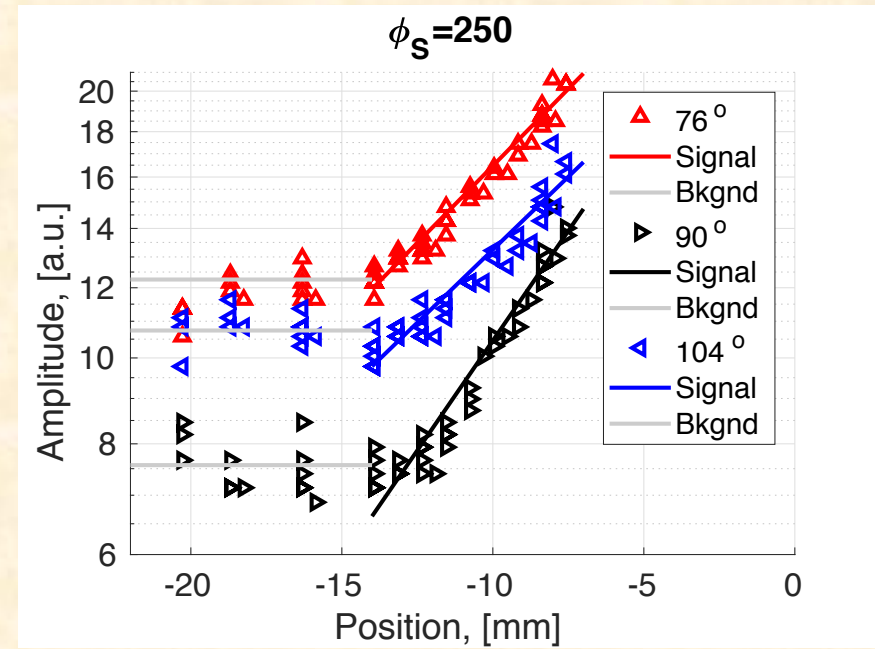
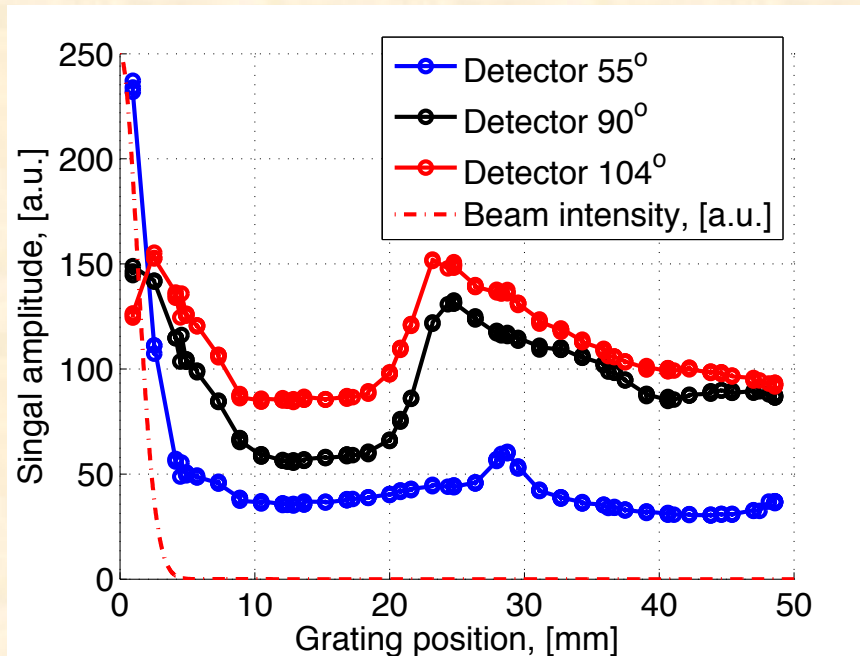

# SP @CLIO: Results (2)

- Accuracy of the results allowed to detect a tilt of the detectors board.

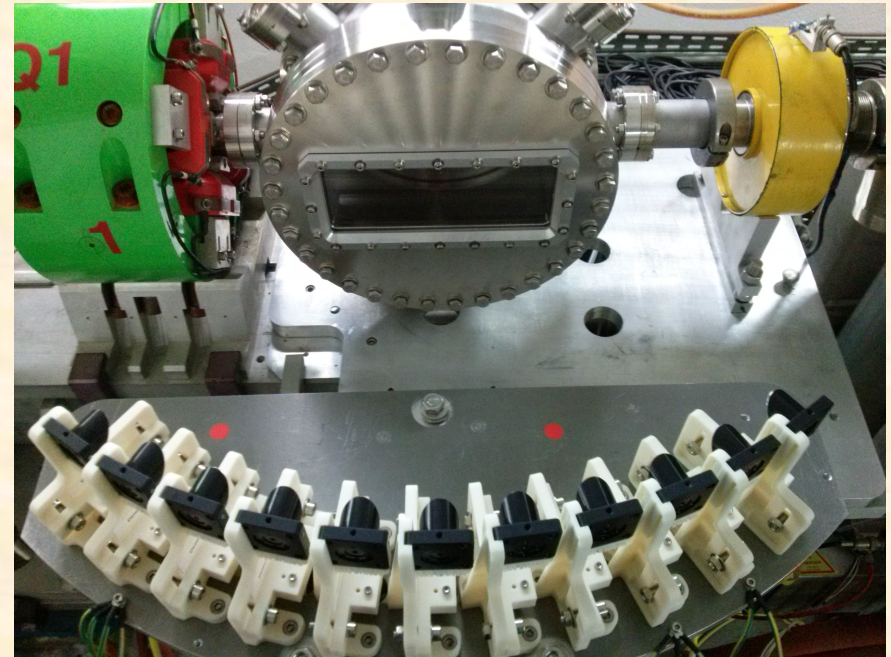
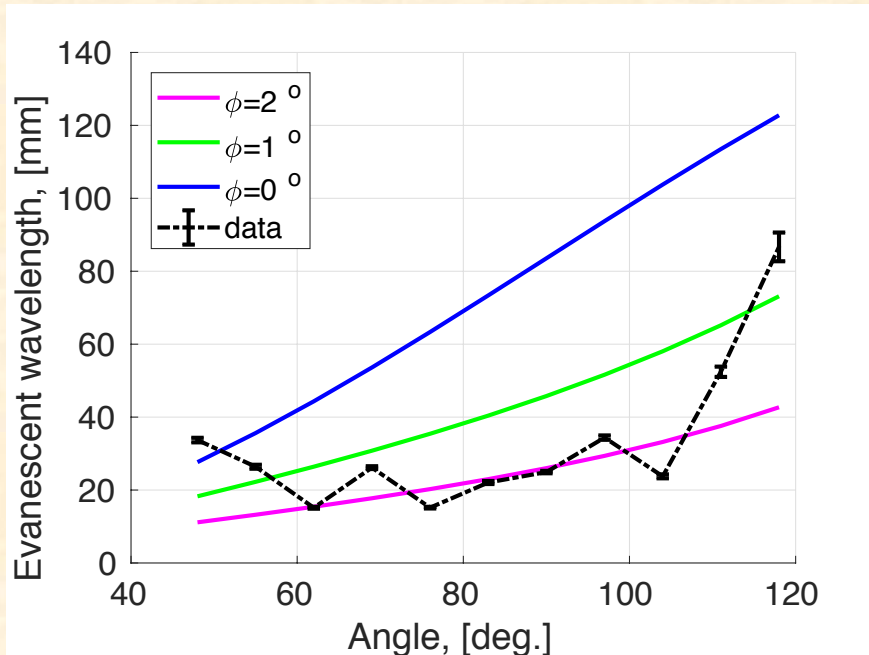

# SP @CLIO: Results (3)

- Profile reconstruction

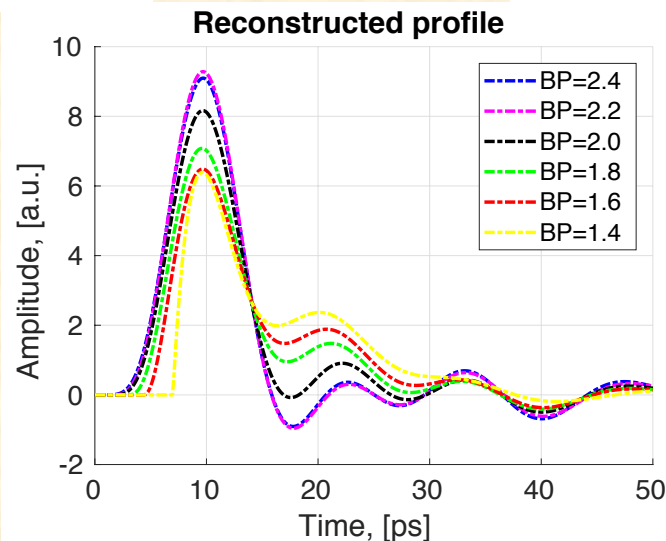
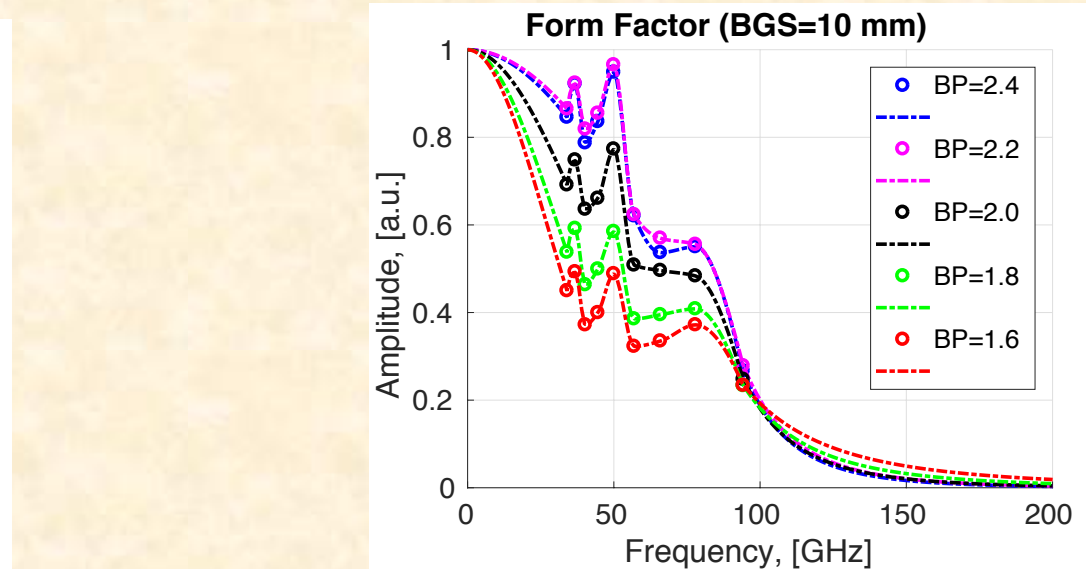
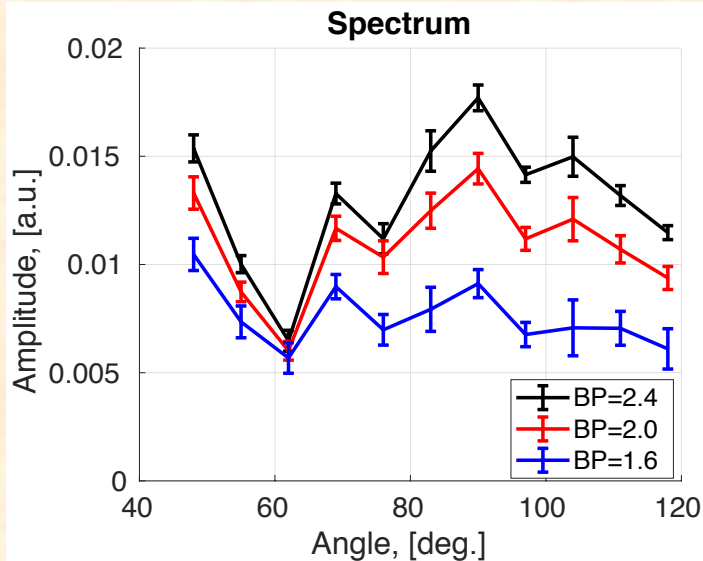



# SP @CLIO: Results (4)

- Results from two different gratings can be stitched together to improve the sensitivity.
- However, this is very artificial as the data were taken on different days.

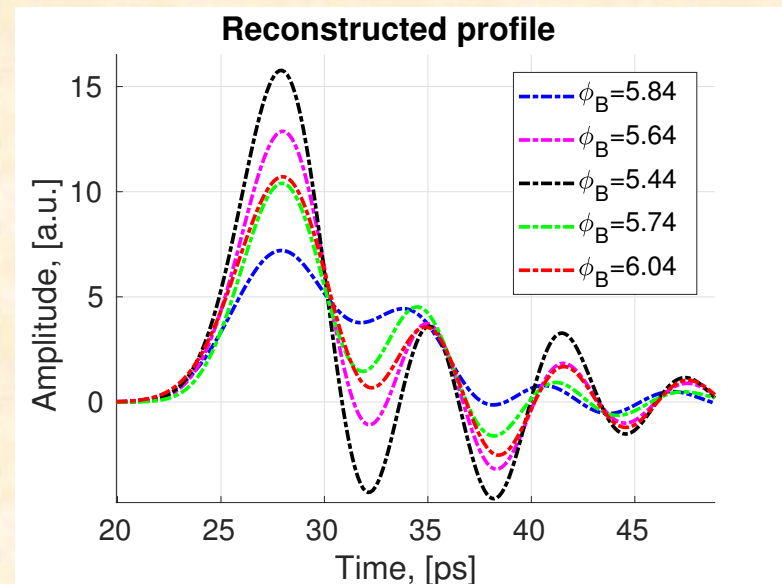
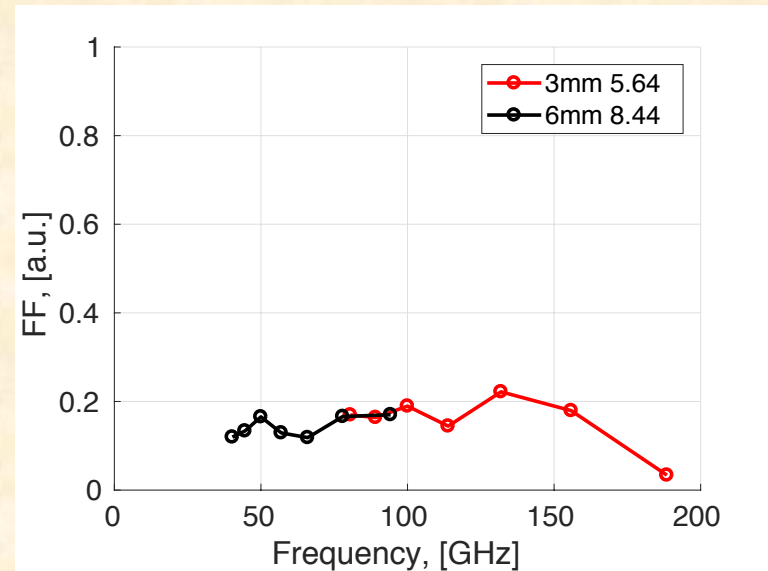

# SP @CLIO: Upgrade

- The vacuum chamber needs to be upgraded.
- This will allow measurement with different gratings within a few minutes of each other.

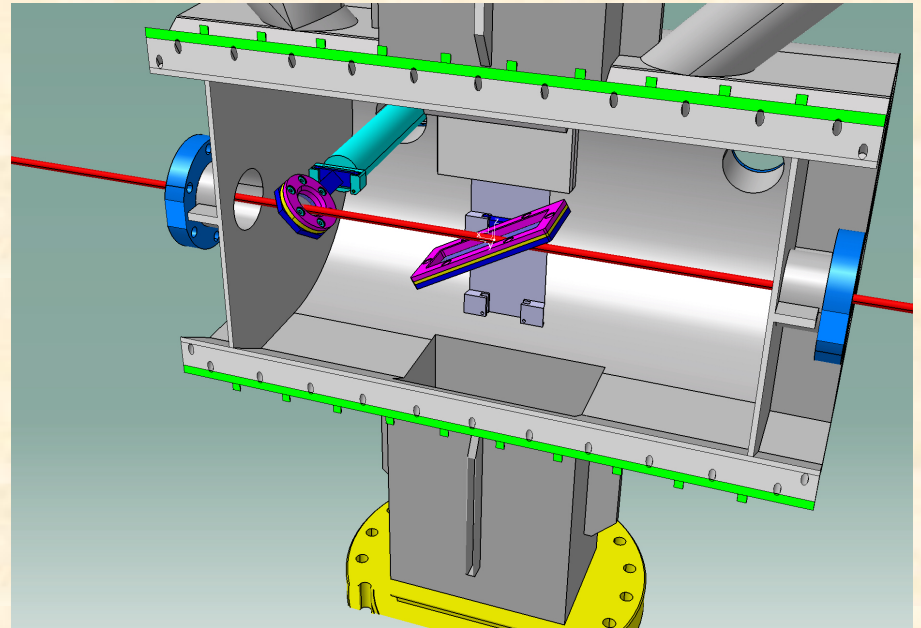
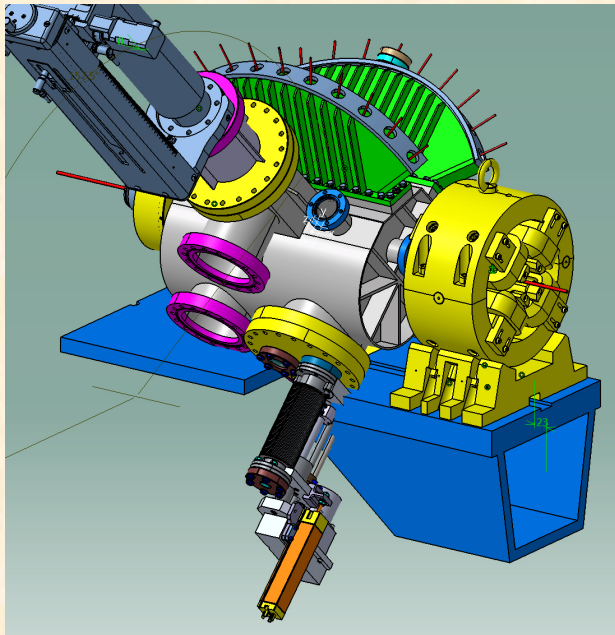

# Outlook

- Smith-Purcell radiation can be used as a bunch length diagnostic.
- Several experiments have been done.
- Next steps:
  - single shot monitor on ps beam at CLIO
  - Single shot on sub-ps beam
- Steady progress but very small team!

Thank you!