

# Crystal-assisted positron source

X. Artru, I. Chaikovska, R. Chehab, M. Chevallier, Y. Han

# Why $e^+$ sources are critical components of the FC

$$L = \frac{N_1 N_2 f n_b}{4\pi \sigma_x \sigma_y}$$

High luminosity at the future colliders  $\Rightarrow$  needs **high average and peak  $e^-$  and  $e^+$  currents and small emittances.**

$\Rightarrow$   $e^+$  are produced within large 6D phase space ( $e^+/e^-$  pairs produced in a target-converter).

• **Current**  $\Rightarrow$  limited in conventional way by the target characteristics

- Average energy deposition  $\Rightarrow$  target heating/melting
- Peak Energy Deposition Density (PEDD): inhomogeneous and instantaneous energy deposition  $\Rightarrow$  thermo mechanical stresses due to temperature gradient
- Thermal dynamics and shock waves
- Fatigue limit resulting from cycling loading.

• **Emittance**  $\Rightarrow$  at the production 6D phase space is very large

- After defined by the  $e^+$  capture system acceptance.

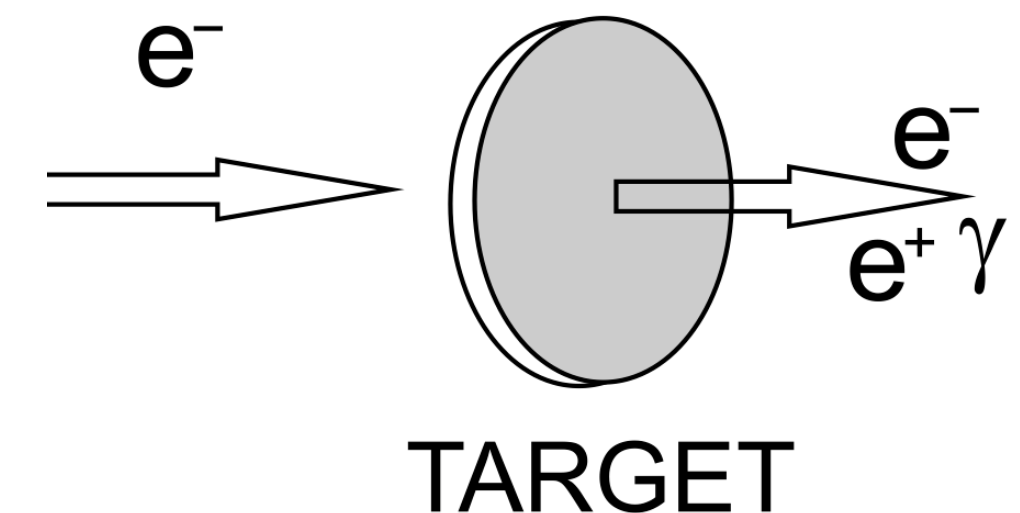

$e^+$  source fixes the constraints for the peak and average current, the emittance, the damping time, the repetition frequency  $\Rightarrow$  **Luminosity!**



# What are the main challenges

- **High intensity** => 1) number of  $e^+/e^-$  pairs: higher primary beam energy and intensity, rather thick targets-converter or photon radiators (channeling, undulators) + 2) capture system (B field and RF sections)
- **Emittances** => weak multiple scattering => towards thin targets and small beam sizes on the targets + capture system
- **Polarization** => need the circularly polarized photon beam (Compton scattering, helical undulator, polarized bremsstrahlung)
- **Reliability and radiation environment** => prevent target failure (heat & stress) as a function of primary beam size and power. Minimize, whenever possible, the radiation load on the environment. Ensure remote handling / target removal system.

Positron emittance at the exit of the target, the AMD and the capture section at 200 MeV

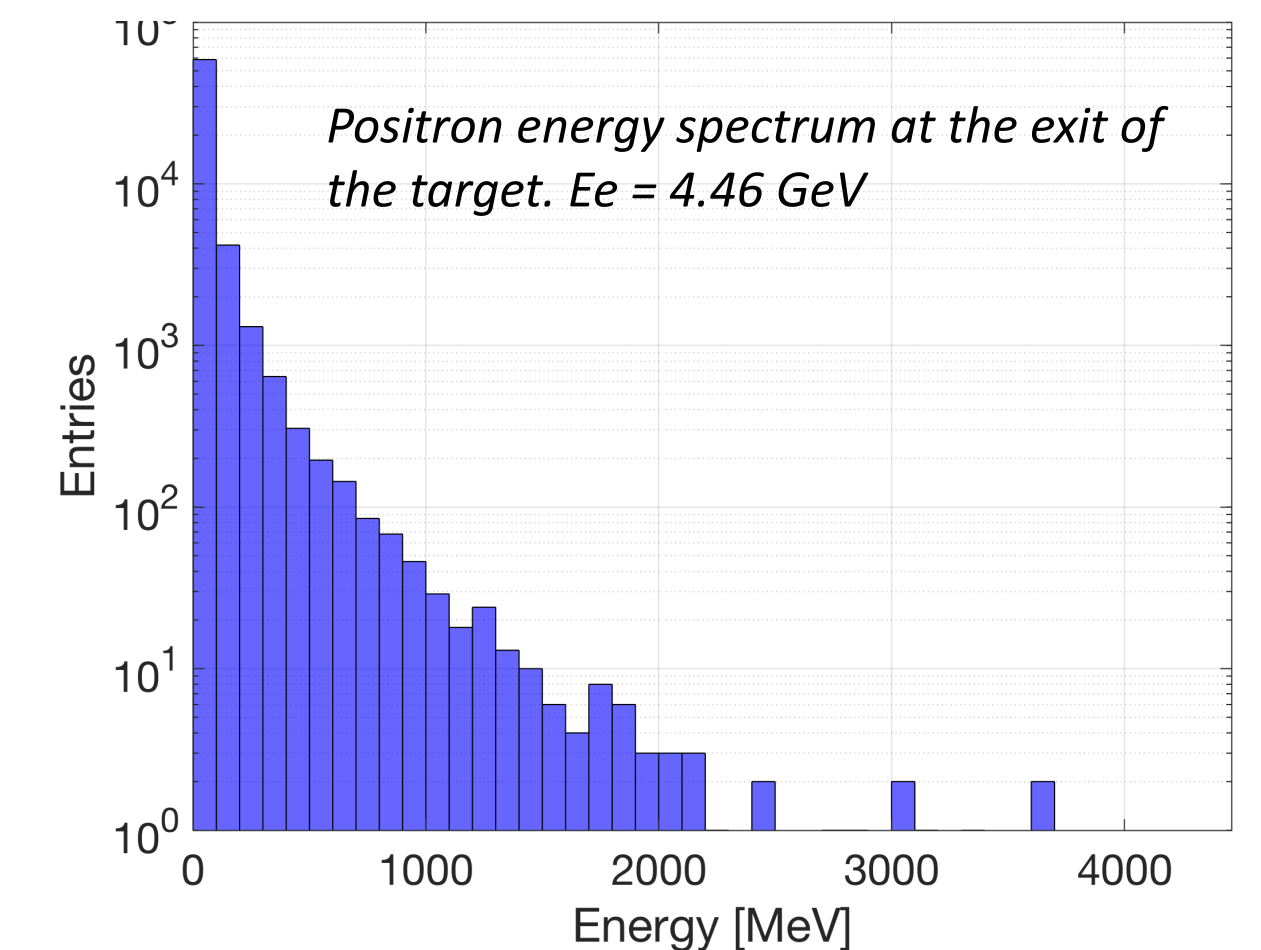
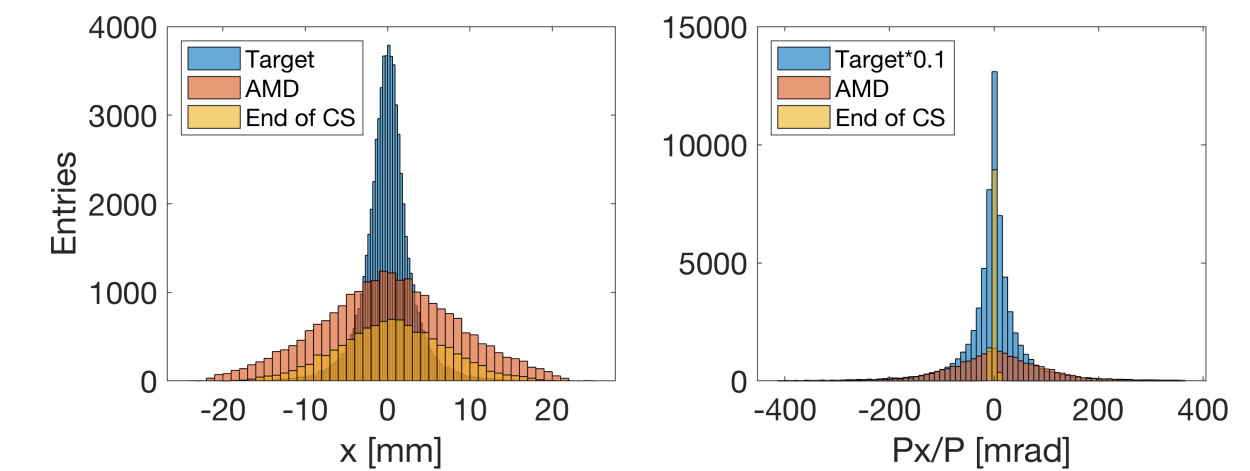
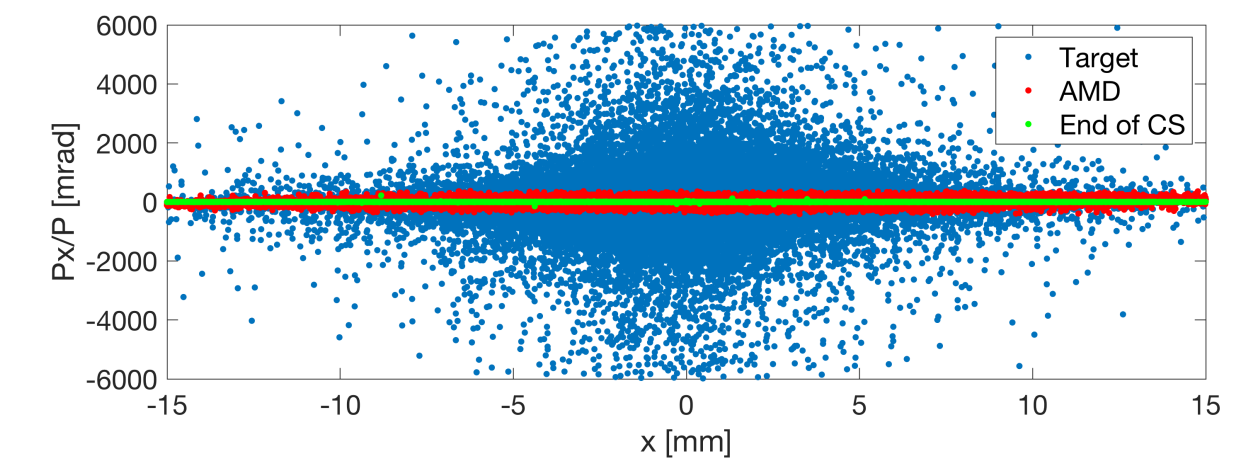

# Positrons sources: classical scheme

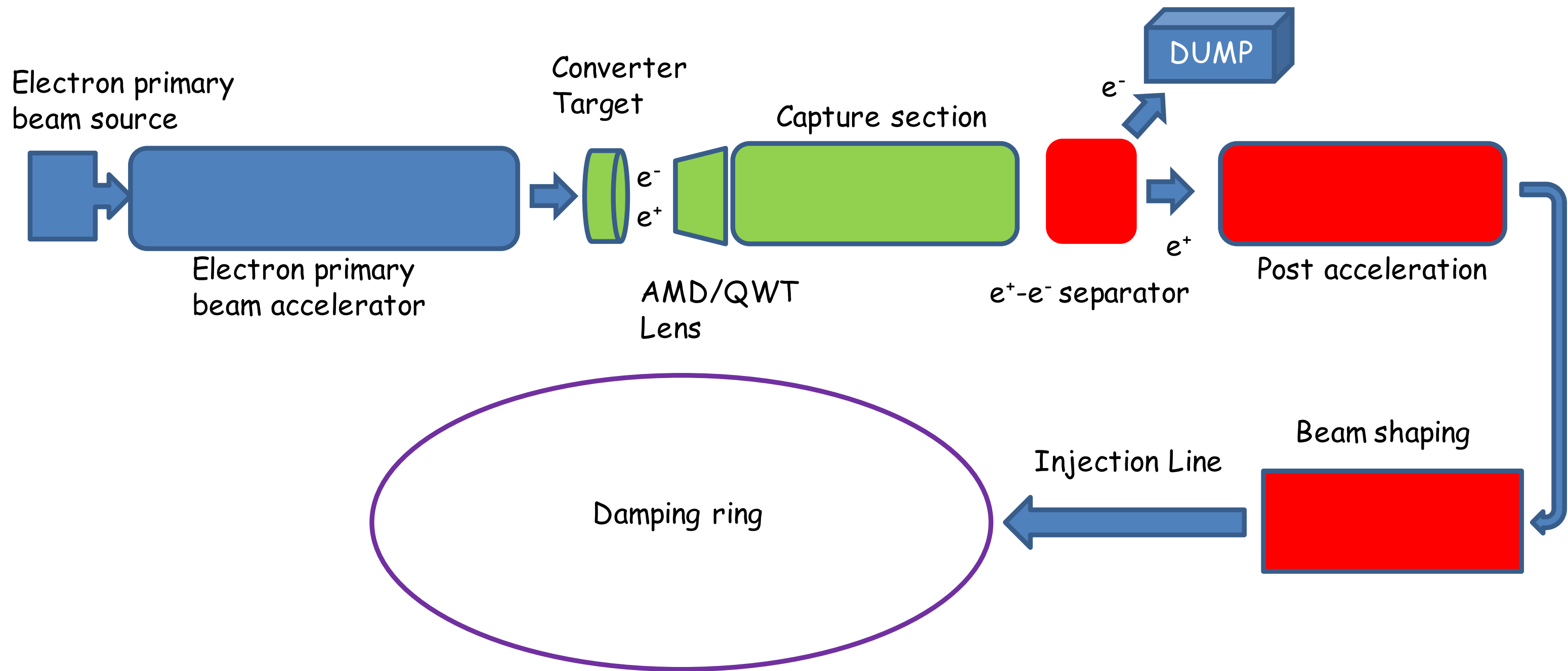

High production  $e^+$  divergence  $\Rightarrow$  appropriate capture, focusing and post acceleration sections need to be integrated immediately after the target.

**Goal:** matching the  $e^+$  beam (with very large transverse divergence) to the acceptance of the pre-injector linac.

**Accepted  $e^+$  flux is a function of target + capture system + primary beam characteristics!**

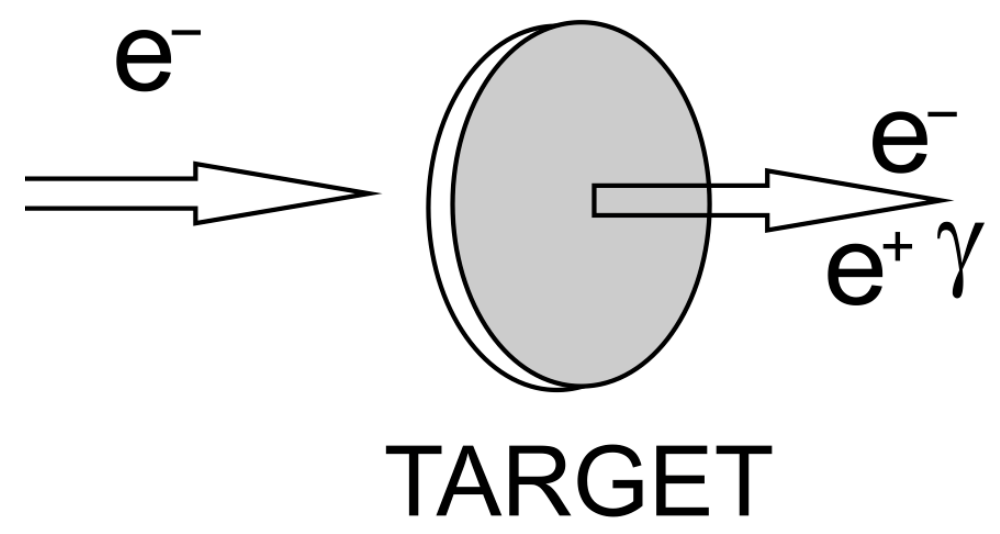

**Conventional positron target: bremsstrahlung and pair conversion**

- Classical  $e^+$  source
- It was employed to produce  $e^+$  beam at the existing machines (ACO, DCI, SLC, LEP, KEKB...)



# Positron source performances

**Demonstrated (a world record for the existing accelerators): SLC e+ source:  $\sim 0.08e14$  e+/s**

Facility	PEP-II	KEKB	DAFNE	BEPC	LIL	CESR	VEPP-5
Research center	SLAC	KEK	LNF	IHEP	CERN	Cornell	BINP
Repetition frequency, Hz	120	50	50	12.5	100	60	50
Primary beam energy, GeV	33	3.7	0.19	0.14	0.2	0.15	0.27
Number of electrons per bunch	$5 \times 10^{10}$	$6 \times 10^{10}$	$1.2 \times 10^{10}$	$5.4 \times 10^9$	$3 \times 10^9$	$3 \times 10^{10}$	$2 \times 10^{10}$
Target	W-25Re	W	W-25Re	W	W	W	Ta
Matching device	AMD	QWT	AMD	AMD	QWT	QWT	AMD
Matching device field, T	6	2	5	2.6	0.83	0.9	10
Field in solenoid, T	0.5	0.4	0.5	0.35	0.36	0.24	0.5
Capture section RF frequency, MHz	S-band	S-band	S-band	S-band	S-band	S-band	S-band
Positron yield, 1/GeV	0.054	0.023	0.053	0.014	0.0295	0.013	0.1
Positron output, 1/s	$8 \times 10^{12}$	$2 \times 10^{11}$	$2 \times 10^{10}$	$2.5 \times 10^8$	$2.2 \times 10^{10}$	$6.6 \times 10^{10}$	$10^{11}$

# Future Collider project challenges

	SLC	CLIC (380 GeV)	ILC (250 GeV)	LHeC (pulsed)	LHeC (ERL)	LEMMA	FCC-ee
e- beam energy(GeV)	45.6	380	250	140	60	45 (e+)	45.6 (Z)
Norm. hor. emitt. (mm.mrad)	30	0.92	5	100	50	18	24.1
Norm. vert. emitt. (mm.mrad)	2	0.02	0.035	100	50	18	89
Bunches/macropulse	1	352	1312	10 <sup>5</sup>			2
Repetition Rate	120	50	5	10	CW		200 (Inj)
Bunches/second	120	17600	6560	10 <sup>6</sup>	20×10 <sup>6</sup>		16640
e+/second (10 <sup>14</sup> )	0.08	1.1	1.3	18	440	100	0.06@Inj
Polarization	No	No/Yes	Yes	Yes	Yes	No	No

- *Linear Collider projects*: high request for polarization, requested intensity should be produced in “one shot”.
- *Circular Collider projects*: polarization is under discussion, requirements are relaxed due to stacking and top-up injection.
- *Muon colliders (LEMMA)*:  $\sim 1e16$  e+ /s to be defined based on the adopted baseline.



# Positrons sources: 'novel' schemes

**Better solution:** Two-stage process to generate the positron beam

First stage:  $\gamma$ -ray generation

Second stage:  $e^-/e^+$  and  $\gamma$ -ray beams are separated and the latter is sent to the target-converter

The  $\gamma$ -rays can be generated by the following methods:

- **Radiation from helical undulator**
- **Channeling radiation**
- **Compton scattering**

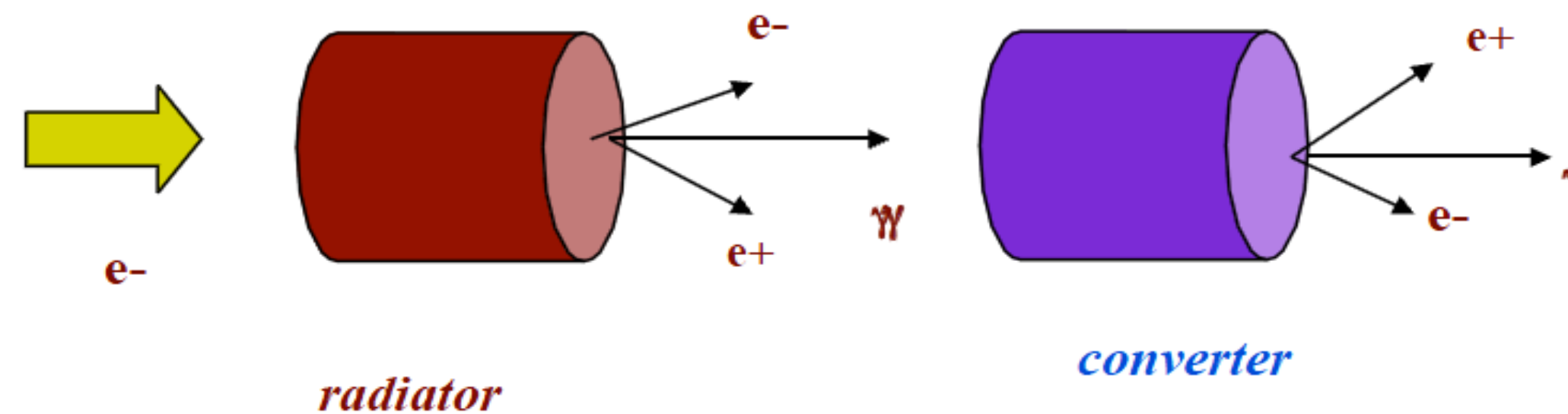

Two targets are used: a *radiator* to produce the photons and a *converter* for the materialization of the photons in  $e^+e^-$  pairs

Charged particles are swept off => the deposited power and PEDD are strongly reduced

# Positron sources using channeling

Originally proposed by LAL group + Xavier Artru (IPNL)

(R. Chehab et al., in Proc. of the 1989 IEEE Particle Accelerator Conf., 1989, pp. 283–285)

- **Hybrid scheme** is based on a relatively new kind of  $e^+$  source using the intense radiation emitted by high energy (some GeV) electrons channeled along a crystal axis => channeling radiation.

*Radiator is an oriented crystal and  $e^-/e^+$  pairs are generated in the amorphous converter.*

## Planar vs. Axial channeling:

- Axial potentials are generally 5 to 10 times stronger than planar potentials.
- As radiated energy is proportional to the square of the channeling field => *axial channeling* is preferred for  $\gamma$ -radiation in a *positron source*.

- W crystal: the potential depth  $U_0$  is of 1 kV at normal temperature. The angle of incidence of the  $e^-$  on the atomic rows should be smaller than the Lindhard critical angle:  
 $\theta < \Psi_c = [2U/E]^{1/2}$
- The frequency of the radiated photon is given approximately by  $\omega = 2\gamma^2 \Delta E_T$

## @ 1GeV for W

- $\Psi_c = 1.4$  mrad
- $\Delta E_T$  is of some eV  
=>  $\omega \sim 40$  MeV

# Channeling vs. Bremsstrahlung

- For targets of the same thickness there is an enhancement of *the soft photons* production in the crystal oriented on its  $\langle 111 \rangle$  axis compared to the amorphous.
- *Soft photons* will generate the *soft positrons* => easier to capture by matching devices.
- There is a threshold in energy, for which the energy radiated by channeling becomes more important than that of bremsstrahlung.
- It depends on crystal: for W,  $E > 700$  MeV. For other crystals (Si, Ge, C(d)) the threshold is higher.

V N Baier, Katkov, V M Strakhovenko, 1986 Phys. Stat. Solidi B 133, 583

Proof-of-principle experiment in Orsay (1992-1993): observing radiation enhancement in a tungsten crystal oriented along the  $\langle 111 \rangle$  axis submitted to a 2 GeV electron beam.

X. Artru et al., *NIM Section B*, 119.1 (1996): 246-252.

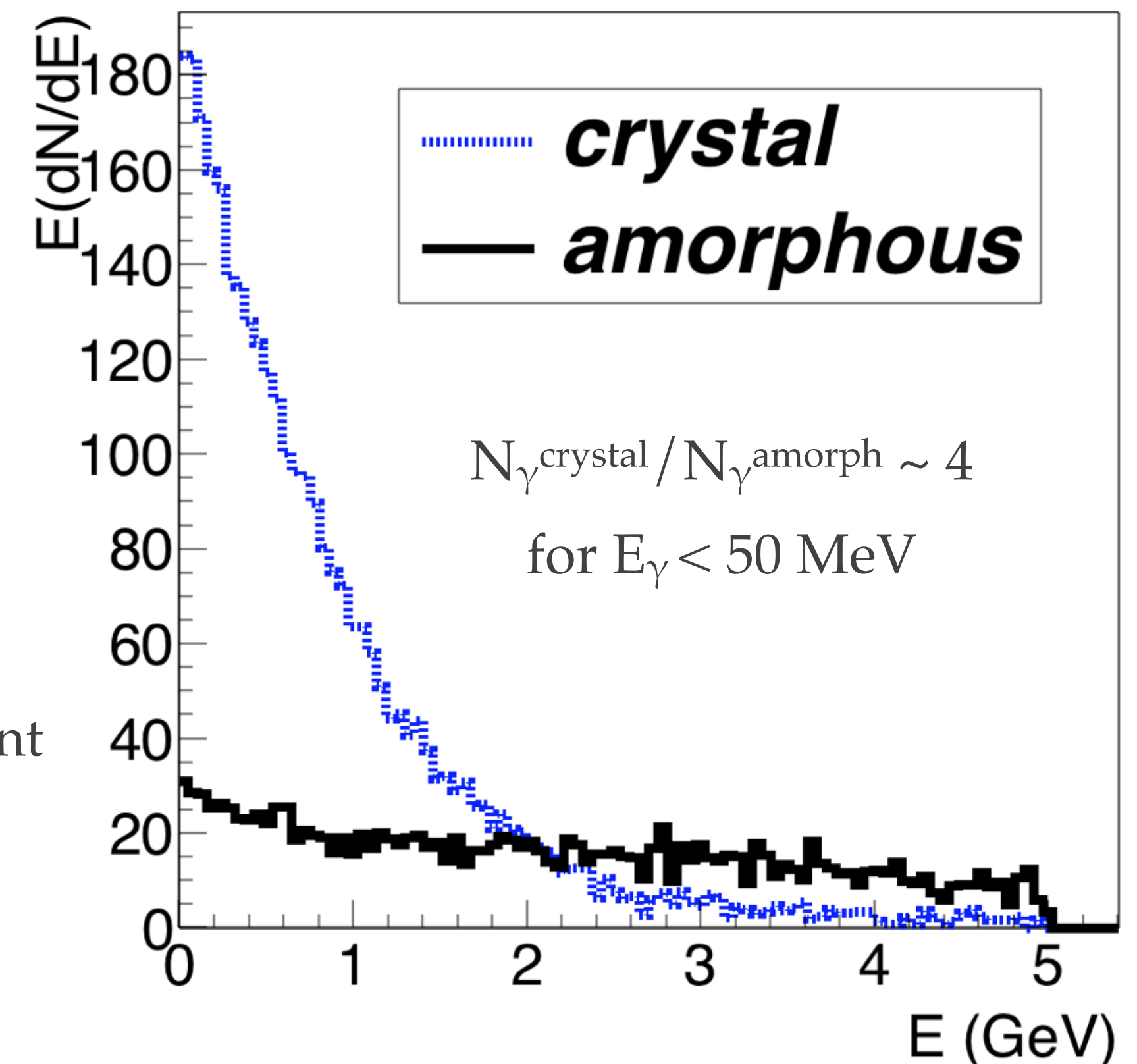
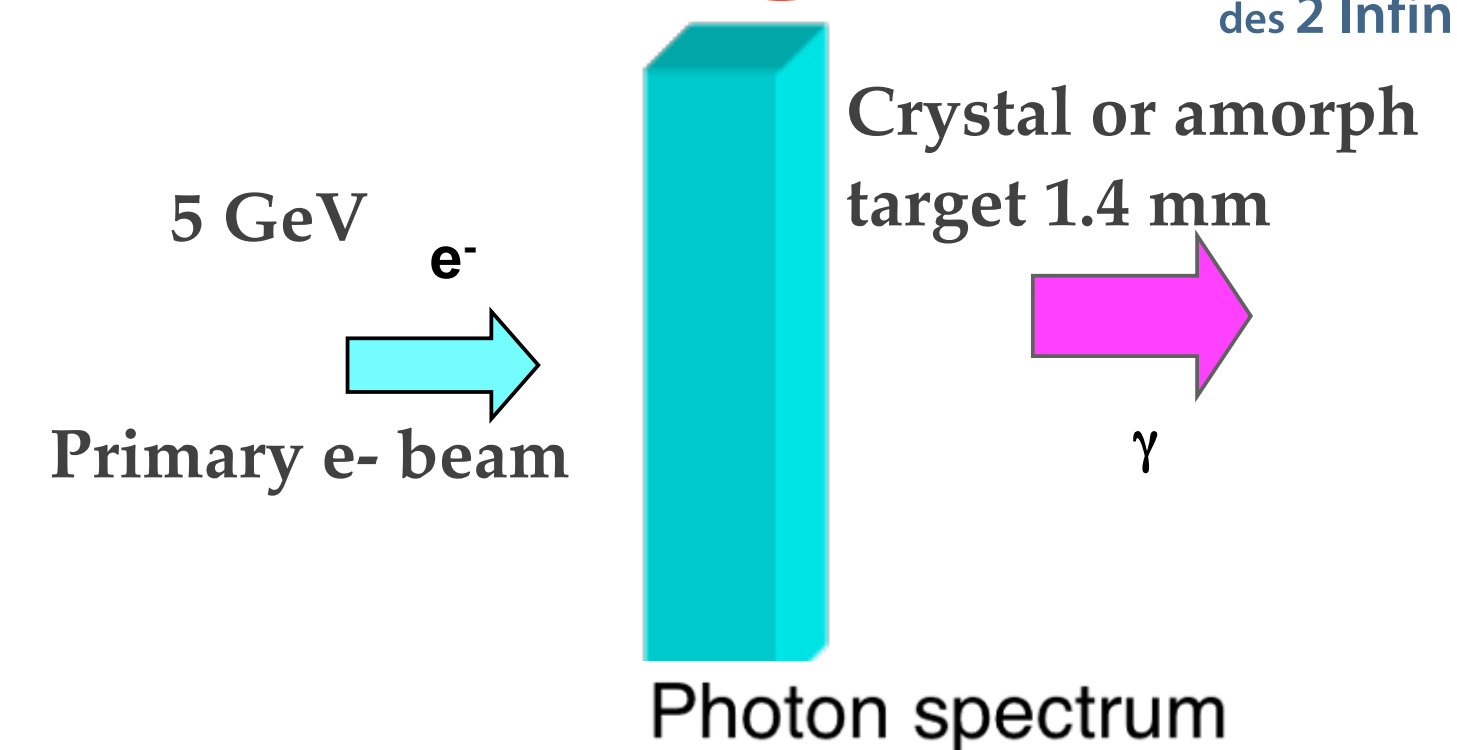



# Positron Sources using channeling

- **Thick crystals:** radiation and conversion in the same target

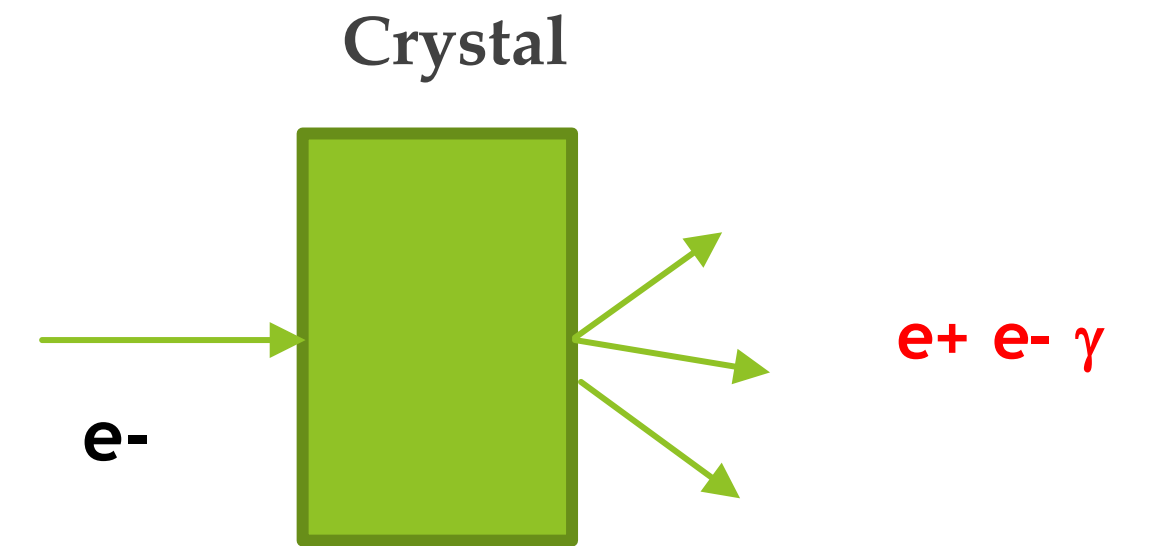

- **Hybrid scheme:** thin crystal radiator & thick amorphous converter

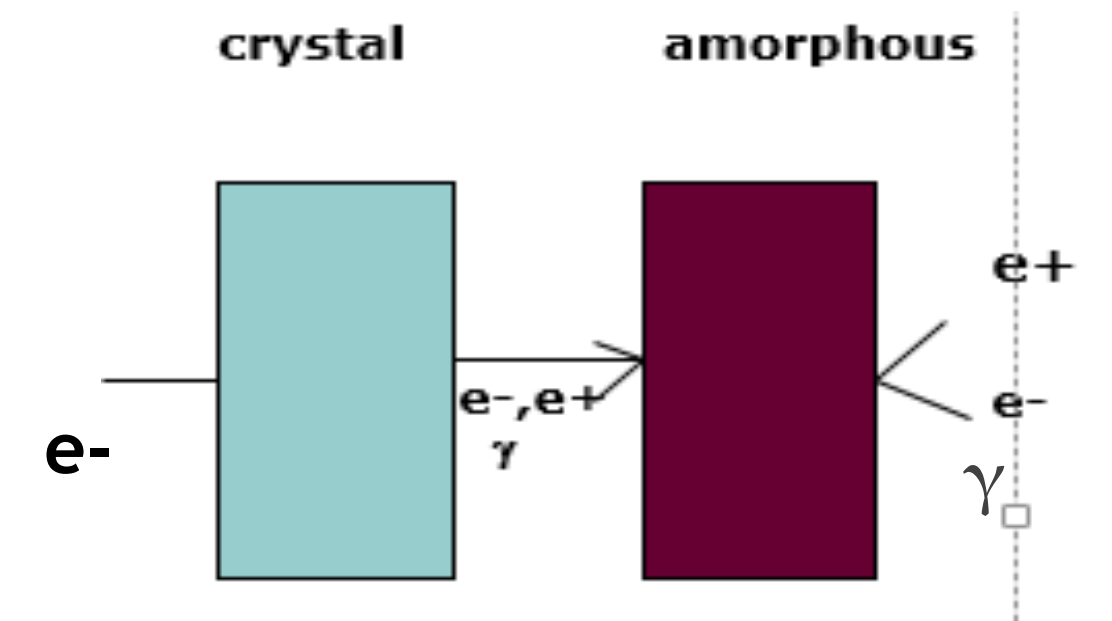

- **Optimized hybrid scheme:** decrease of the deposited energy by sweeping off the  $e^+ / e^-$  (from crystal)

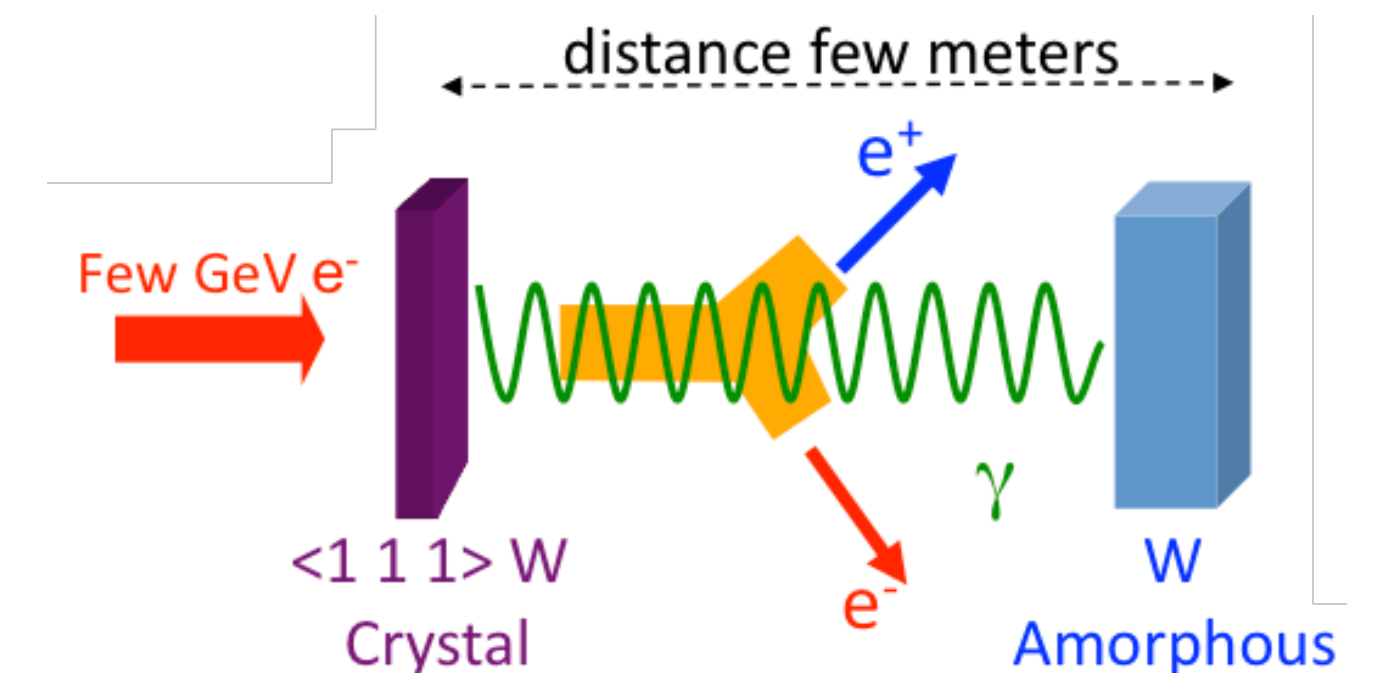

*Three approaches have been studied experimentally*



# Positron Sources using channeling

## Crystal converter vs. Hybrid source

☞ Several experiments have been carried out at CERN and KEK with different configuration.

### Experiment WA103 at CERN

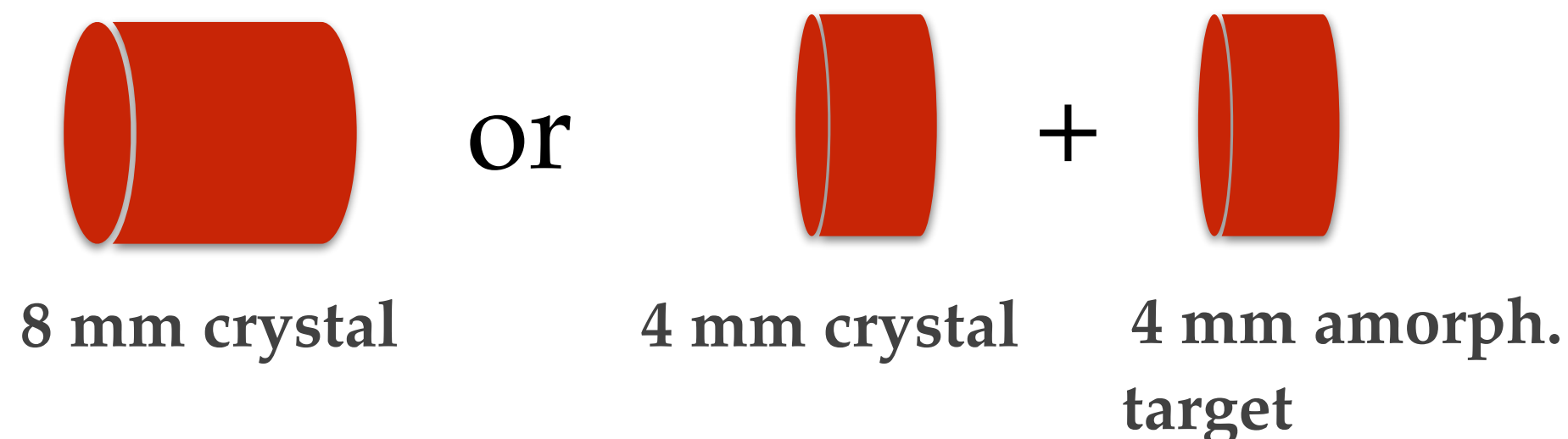

- Both types of targets have been tested at CERN.
- The positron yield was the same for 8 mm crystal and [4 mm crystal + 4 mm amorphous converter]. There is an optimum thickness  $< 4$  mm.
- Further calculations indicated  $d_{opt} < 2$  mm. For future hybrid sources based on W crystals, at the same incident energy ( $< 10$  GeV) we shall consider 1-2 mm thick crystals (cf. ILC and CLIC).

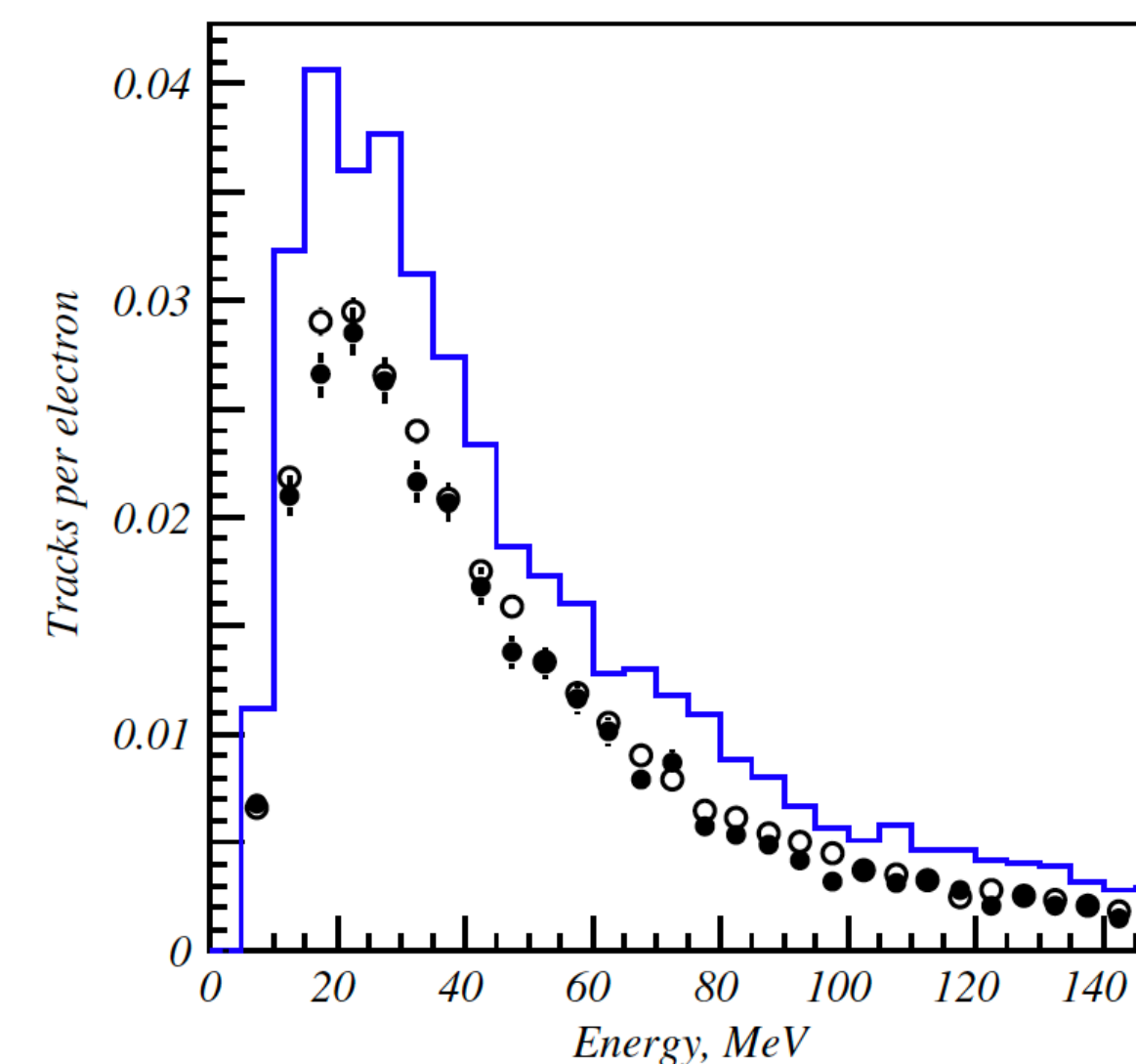

Fig. 12. The positrons energy spectra for the 1 kG magnetic field normalised per 1 incident electron. The spectra are not corrected by the reconstruction efficiency and the detector acceptance. The dark points represent the 8 mm crystal target. The open points, the “4 mm crystal target + 4 mm amorphous target”. The histogram is the 8 mm crystal simulation. The electron energy is 10 GeV.

X. Artru et al., NIMB 240 (2005) 762

# Positron Sources using channeling

## Advantages of the optimized hybrid scheme

- Thin crystal => higher enhancement, more  $\gamma$  produced per  $e^-$  => less energy deposition => less heating => higher potentials
- Thick amorphous converter: high conversion  $\gamma \rightarrow e^-/e^+$
- Distance between radiator and converter: use dipole magnet to sweep off  $e^+/e^-$  after the crystal => less energy deposition, weaker density: avoids high values of PEDD

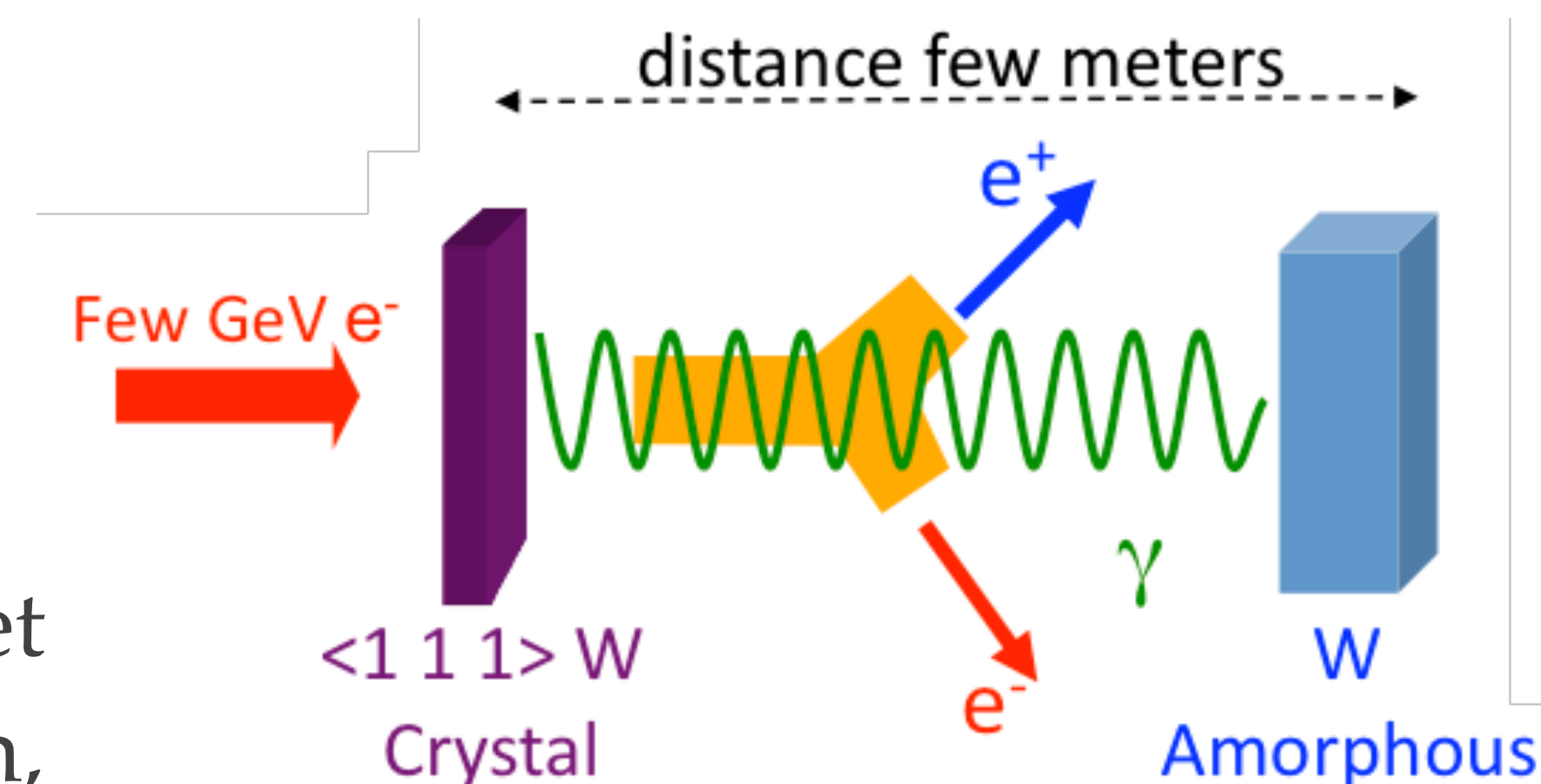

X. Artru et al. NIM B 266 (2008) 3868-3875

*This scheme is proposed to be used for the Future Linear Colliders.*

*A baseline design for the CLIC positron source.*

# Positron Sources using channeling

Optimization of the radiation characteristics for the positron production

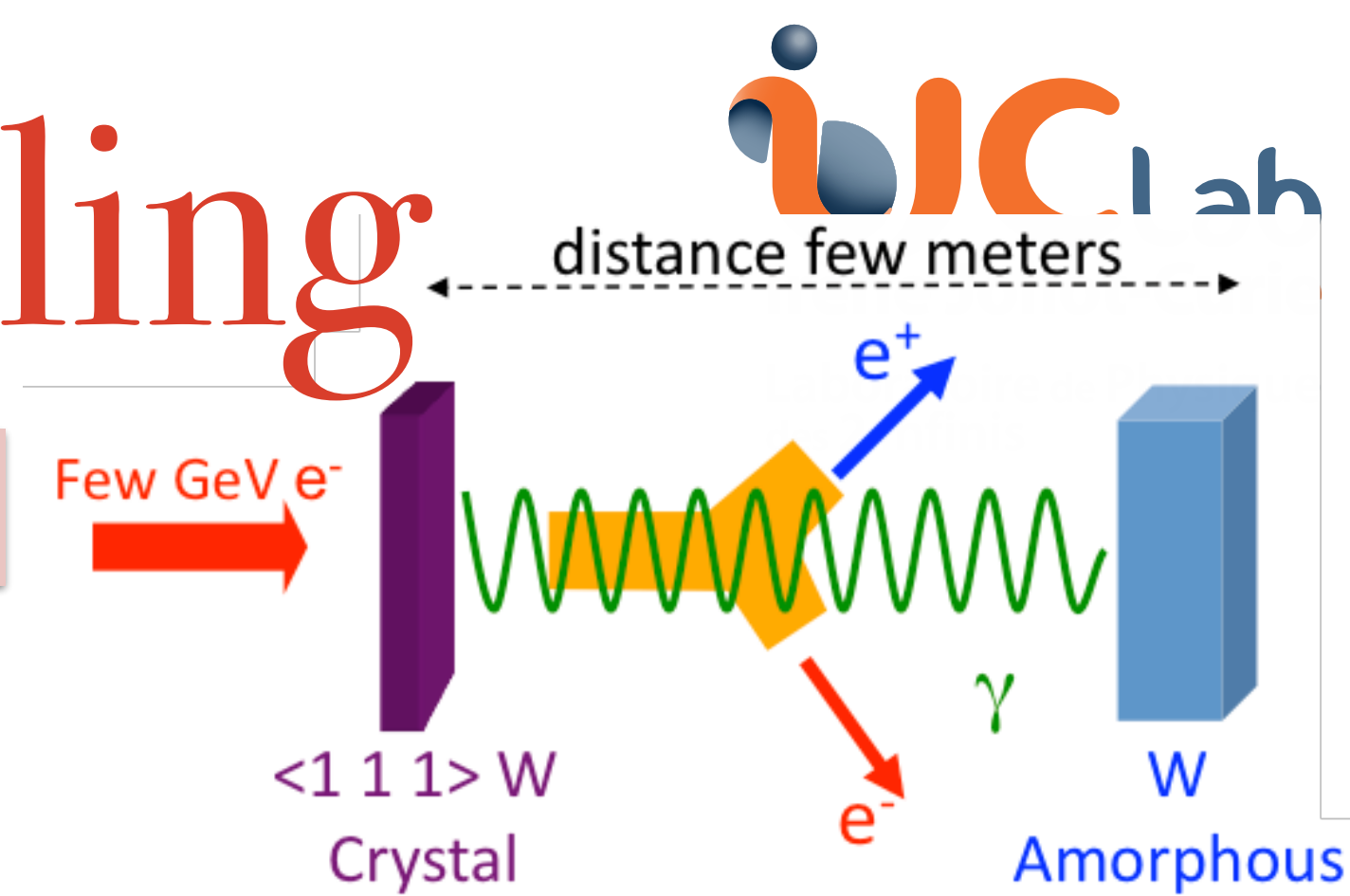

- **Crystal properties**

- *Crystal quality*: crystals with good mosaicity (typically 400-500  $\mu$ rad FWHM)
- *Crystal kind and orientation*: high Z materials and axial channeling. Tungsten W => high atomic potential (1 kV) at  $\langle 111 \rangle$  orientation.
- *Thickness of the crystal*: optimum thickness is between 1-2 mm for  $E \leq 10$  GeV
- **Thickness of the amorphous target (high Z material)**: compromise between the requested yield and the amount of deposited energy => what is essential is **the accepted positron yield**
- **Distance between the radiator and converter**: 1) installation of a sweeping magnet 2) increase the size of the photon beam => contribute to lower the deposited energy density
- **Incident e- beam**: some GeV (to get  $U_{ch} \gg U_{bremss}$ ), U is the energy radiated. Incident electron beam with weak divergence  $\theta < \Psi_c$ .



# Reliability of the crystal for $e^+$ production

## Effect of crystal temperature on the positron yield

☞ With temperature, crystal strings undergo thermal vibrations => reduction of the available potential for channeled particles.

- Taking into account the  $U(T)$ , simulations have been undertaken with a W crystal 8 mm thick ( $\langle 111 \rangle$  axis) and  $E_{e^-} = 10$  GeV.
- **Result:** variation of  $\sim 600$  degrees in the crystal decreased the positron yield by 15 %.

### To avoid the potential decrease with increasing temperature:

- It is better to use thin crystals to limit the amount of deposited energy
- the crystal must be cooled (system of many crystals on the translation stage of a goniometer with additional cooling).

$U(eV)$  X.Artru et al. Part. Accel., Vol.59 (1998) 19-41

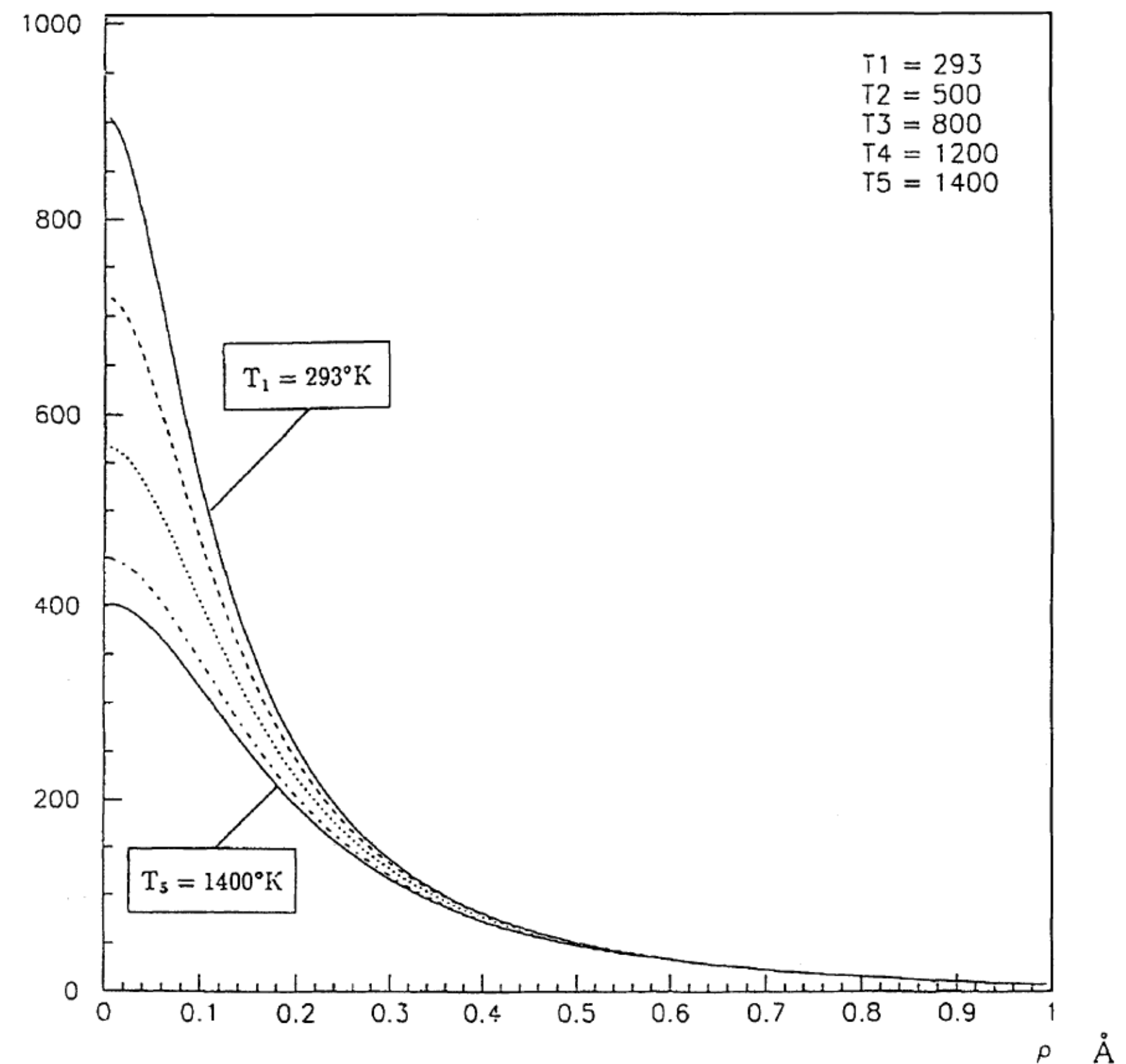

FIGURE 9 Continuum potentials for the  $\langle 111 \rangle$  axis of the tungsten crystal. The temperatures are expressed in K.



# Reliability of the crystal for $e^+$ production

## Radiation damage of the crystal

R.Chehab et al. in Proc. of EPAC 1998

### Radiation damage experiment at SLAC (1996)

In order to study the radiation damages on the W crystal, a thin crystal (0.3 mm thick) has been installed upstream of the SLC  $e^+$  target and irradiated during 6 months.

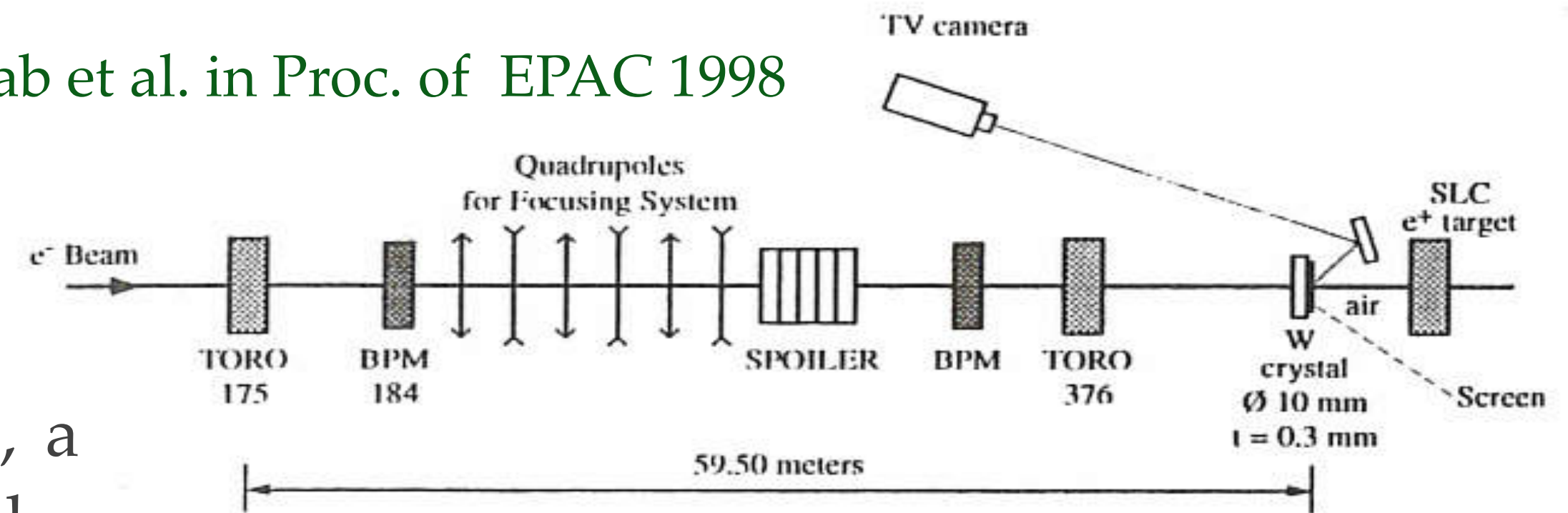

Figure 3: The SLC experimental set-up

- **The SLC beam:**  $E = 29.5$  GeV, average intensity:  $2.5 \times 10^{10}$   $e^-$ /pulse, Frequency: 100 Hz in average, Integrated intensity (6 months):  $1.2 \times 10^{19}$   $e^-$ , Spot area on the crystal:  $6.2$   $\text{mm}^2$ , Total fluence:  $2 \times 10^{20}$   $e^-/\text{cm}^2$
- **Results:** No damage was observed (same rocking curve after and before irradiation). No modification in the mosaic spread of the crystal was observed. The damage threshold should be higher (for  $e^-$ ).

☞ *This fluence corresponds to the level of appearance of damages on a Si crystal hit by 28 GeV and 450 GeV protons (BNL & Fermilab)*

# Hybrid $e^+$ source: applications

KEKB/SuperKEKB  $\Rightarrow$  Crystal  $e^+$  source @KEKB during 1 year.

Experimental R&D program on hybrid scheme

CLIC  $\Rightarrow$  Hybrid scheme

FCC-ee  $\Rightarrow$  Hybrid or conventional scheme

LEMMA  $\Rightarrow$  Hybrid scheme is under consideration

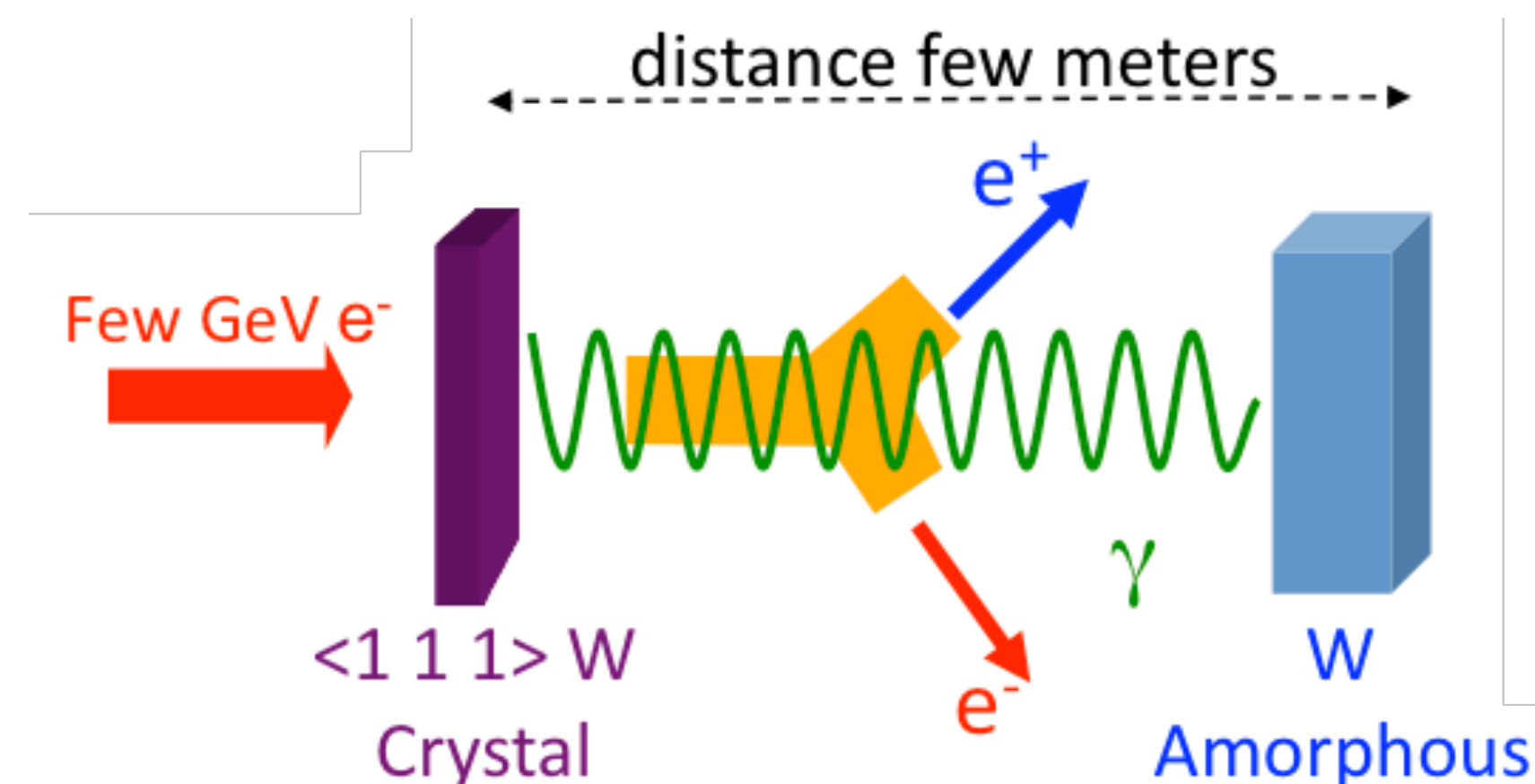

# Crystal $e^+$ source for KEKB

☞ W crystal target has been successfully employed at the  $e^+$  source of the KEKB for 1 year (2006)

- The crystal thickness was 10.5 mm, primary  $e^-$  beam 4 GeV
- The enhancement strongly depends on the crystal thickness (the thicker the crystal, the lower enhancement wrt amorphous target having the same thickness).
- **Results:**
  - At KEKB, the  $e^+$  yield increased by  $\sim 25\%$  compared to that for a conventional tungsten plate with a thickness of 14 mm.
  - The steady-state heat load on the crystal target decreased by  $\sim 20\%$ .
  - After a two-month operation, **no degradation of the  $e^+$  production efficiency was observed.**

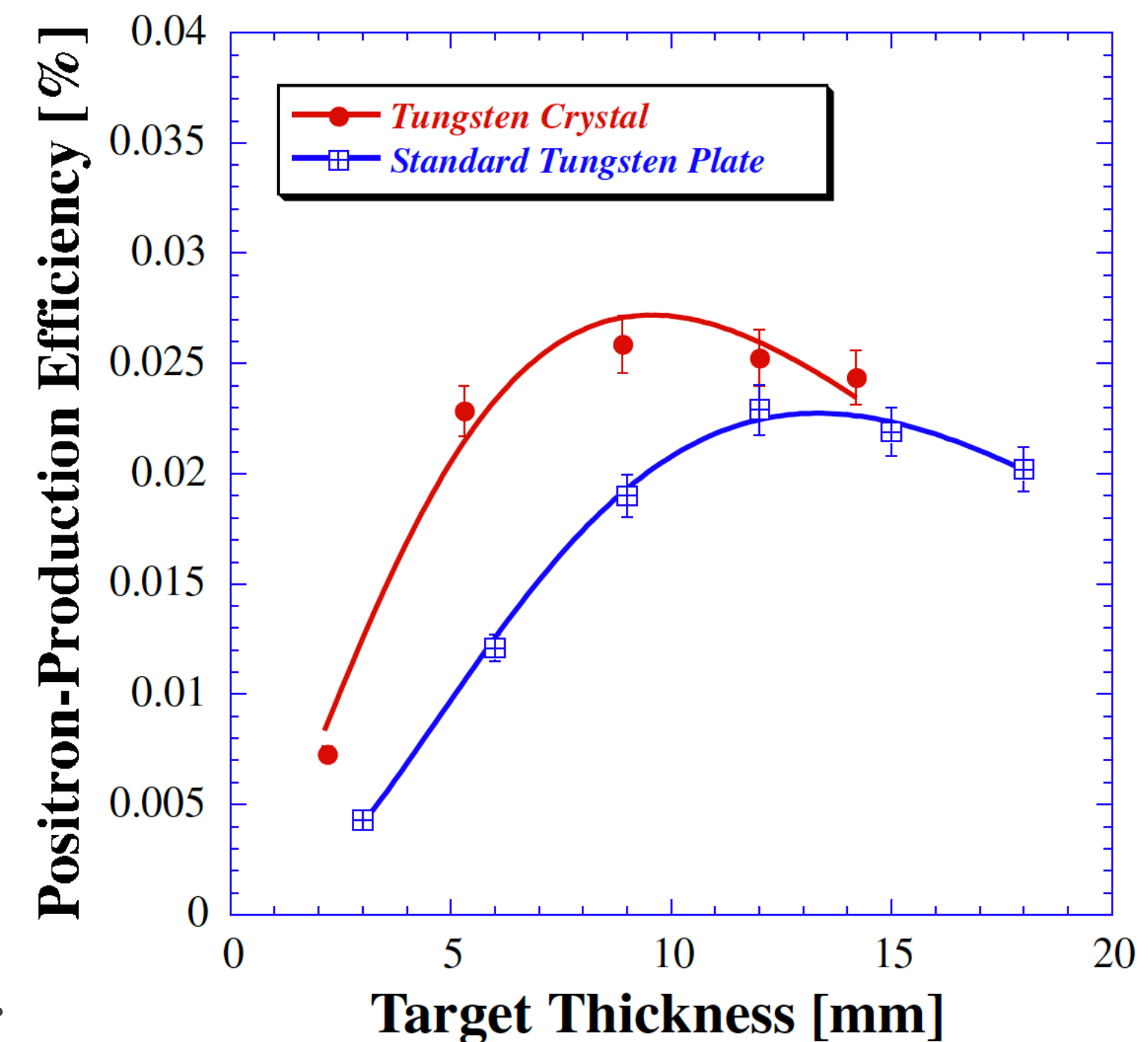

FIG. 2. (Color) Positron-production efficiencies measured for the tungsten crystal as a function of the crystal thickness (see [13] in detail). The incident electron energy and positron momentum were 4 GeV and 20 MeV/c, respectively. The solid curves through the data are gamma-function fits of the data.



# Experimental activity on hybrid source

The experimental activities have restarted in KEK (SuperKEKB injector linac) in 2015/2016. **Goals:** *e<sup>+</sup> yield and target temperature measurements* to compare different targets (Bulk & Granular) => e<sup>+</sup> source performances.

## Experimental conditions:

- Energy = 7-8 GeV, single bunch (Frep = 1 to 50 Hz), Charge = 1-2 nC
- Emittance (norm) ~ 150(H)/63(V) mm mrad, beam divergence < 0.1 mrad
- Crystal W: 1mm thick, <111> orientation
- Granular targets: 4, 6 and 8 layers. Bulk target (reference): 8 mm thick
- Temperature rise on the converter : thermocouples

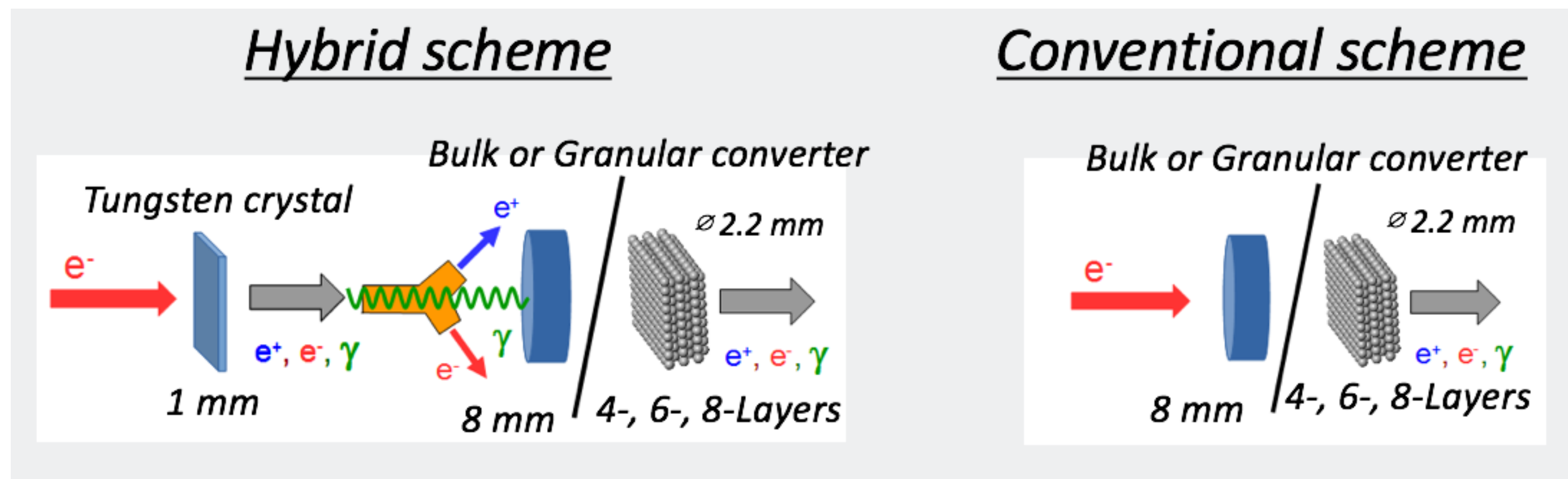
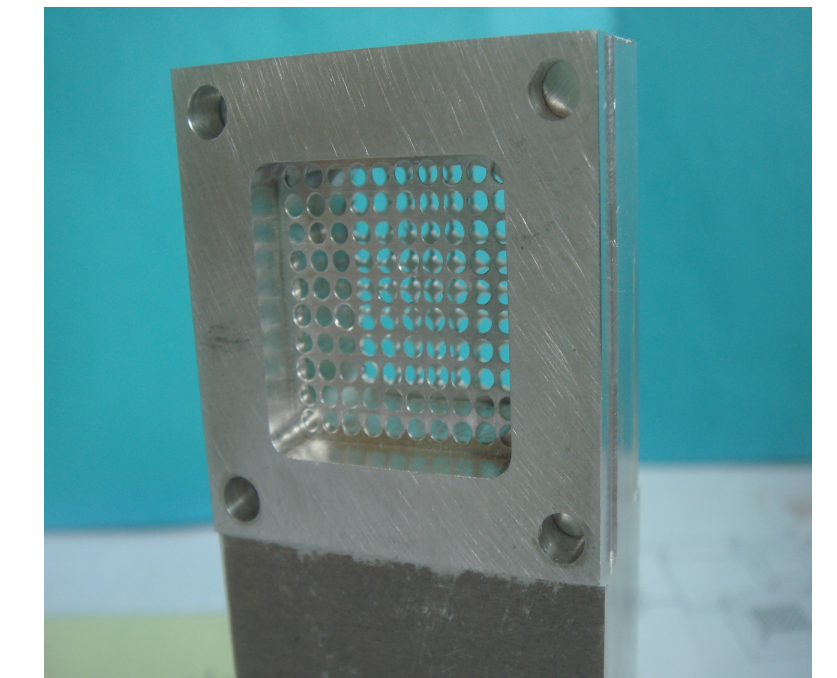
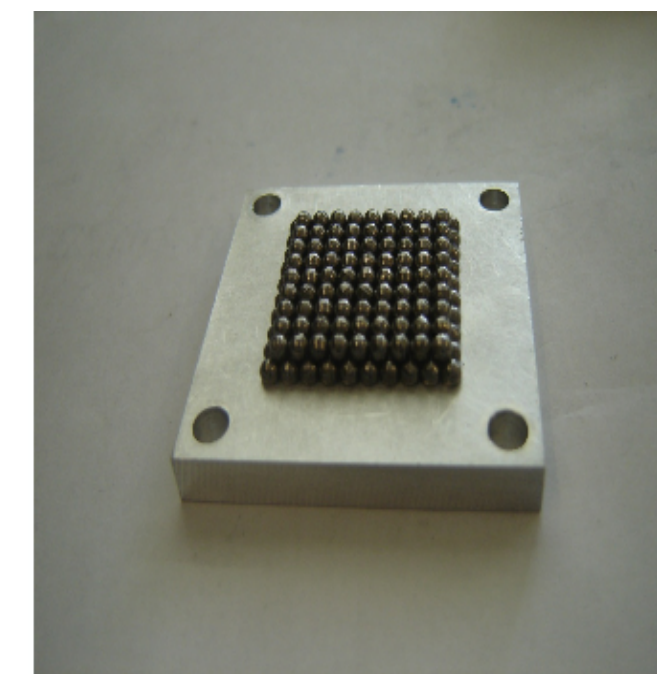



# Experimental activity on hybrid source

## Photons and e<sup>+</sup> detection:

- **Photon detection:** CVD diamond detector 500  $\mu\text{m}$  thick, 4x4 mm<sup>2</sup>. Weak interaction efficiency ( $\sim 0.3\%$ ) but enough  $\gamma$  rays ( $>10^{11}$  per shot)
- **Positron detection:** produced e<sup>+</sup> are analysed by a spectrometer (60° bending magnet) at 5-20 MeV/c and then detected by 5 mm lucite Cherenkov detector

*The e<sup>+</sup> detection system is simulated by using the GEANT4. Typical momentum acceptance is 2.6% (FWHM) at the positron momentum 20 MeV/c. Collaboration with V. Rodin (KNU-Ukraine, Cockcroft Institute-UK).*

## Temperature measurements:

- Standard K-type thermocouples (with area  $< 1\text{ mm}^2$ ) attached to the backside of the targets (glued by an epoxy thermal conductive paste)
- The output has been calibrated (0 -100°C) and sent by a 40 m long extension cables to the experimental room

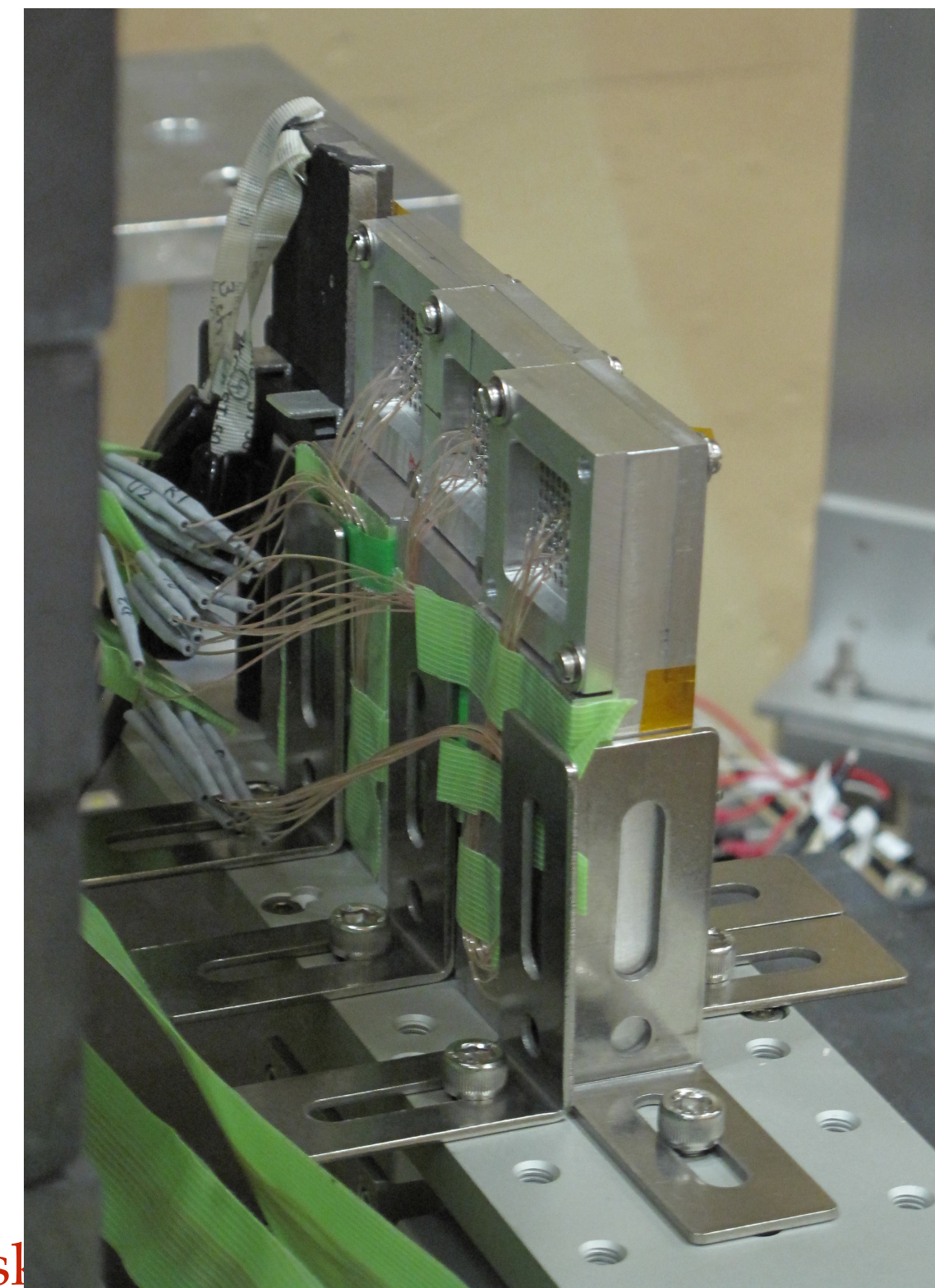







Collimator's systems for selection of required positron beam parameters and decreasing background particles

Bulk target with "ghost" spherical detector

Lucite counter: Detection of particles

Granular target

Magnetic area (hard-edge model) without residual fields

Stainless steel beam pipes in magnetic field area.

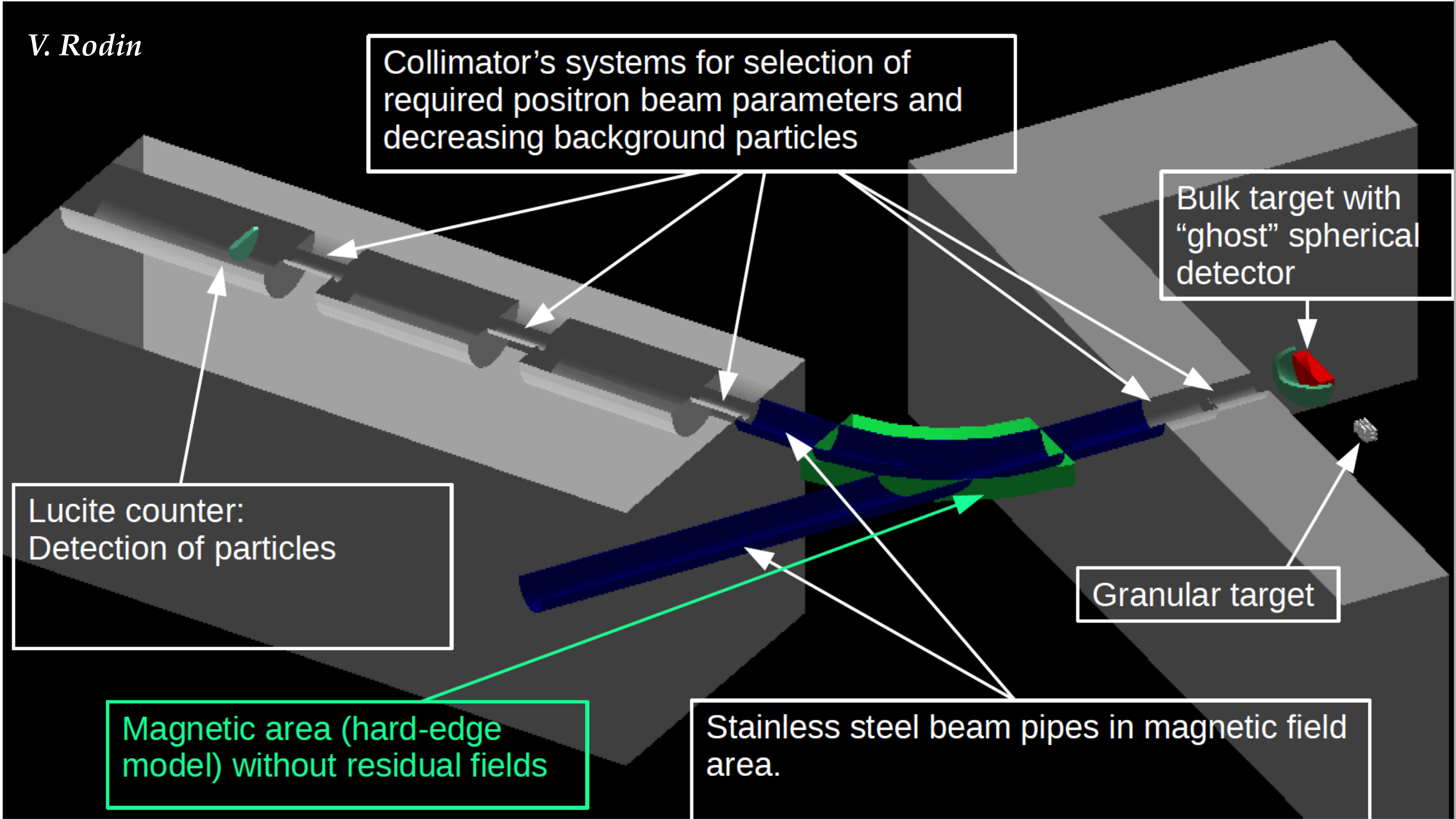



# Experimental activity on hybrid source

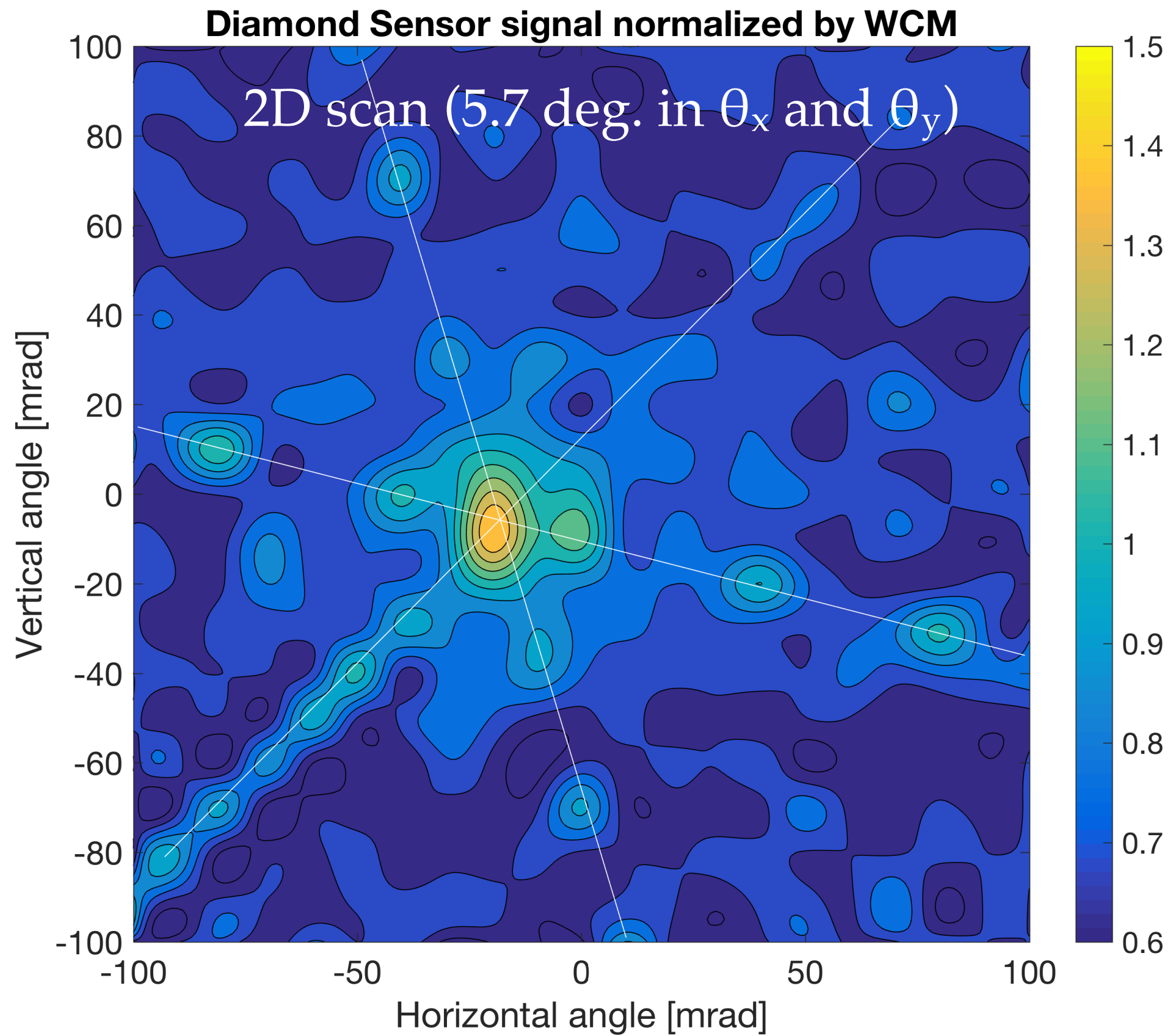

## STEREOGRAPHIC PROJECTION

$\langle 110 \rangle$  axis is at 35.2 degrees from  $\langle 111 \rangle$  and  $\langle 100 \rangle$  axis is at 54.7 degrees from  $\langle 111 \rangle$

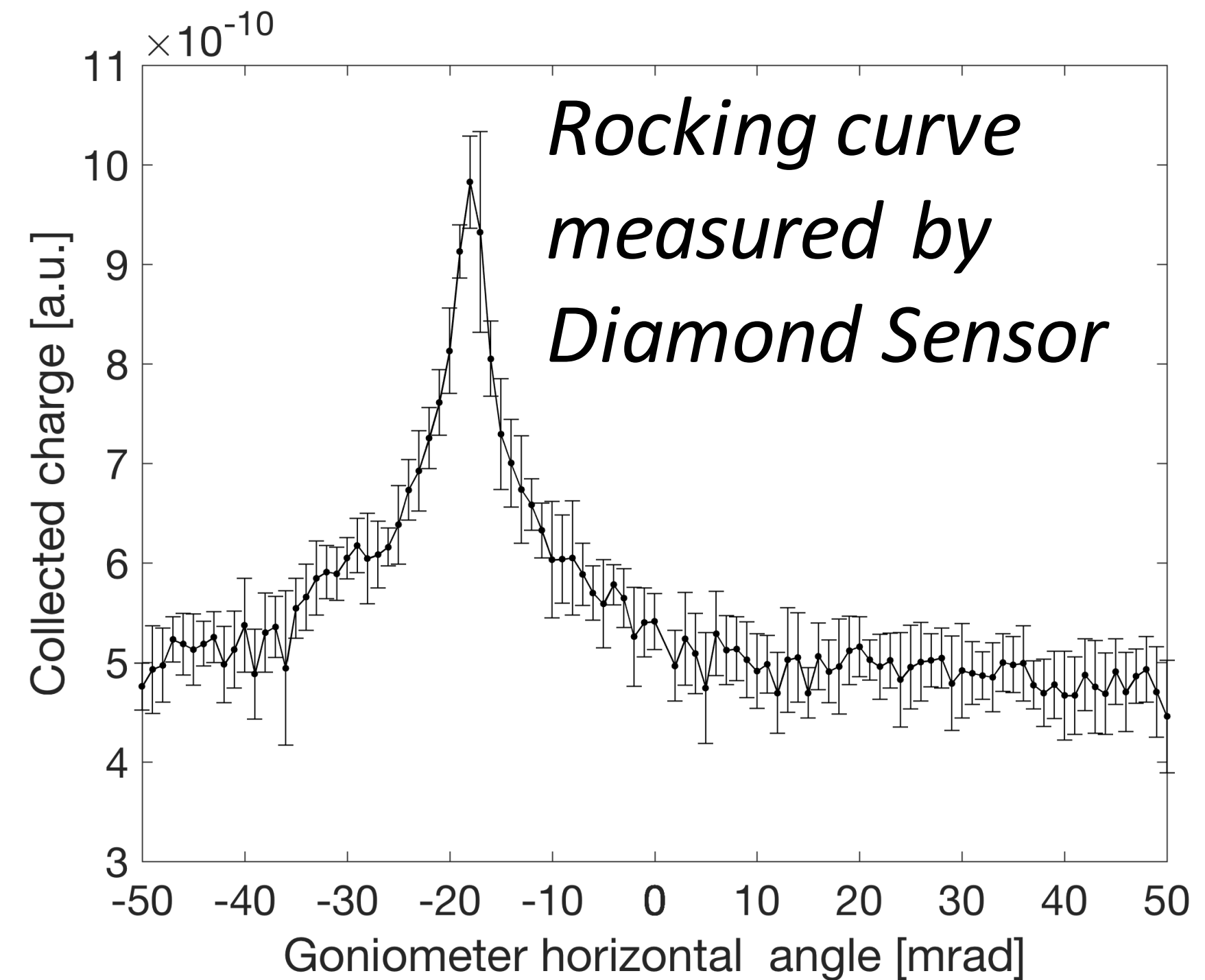

To align  $\langle 111 \rangle$  crystal axis with respect to the electron beam, a 2D angular scan has been performed.

Data suggest an increase by a factor of two in the photon production => the simulations and further analysis of the background are under way to describe the experimental data.

# Experimental activity on hybrid source

Bunch-by-bunch temperature rise

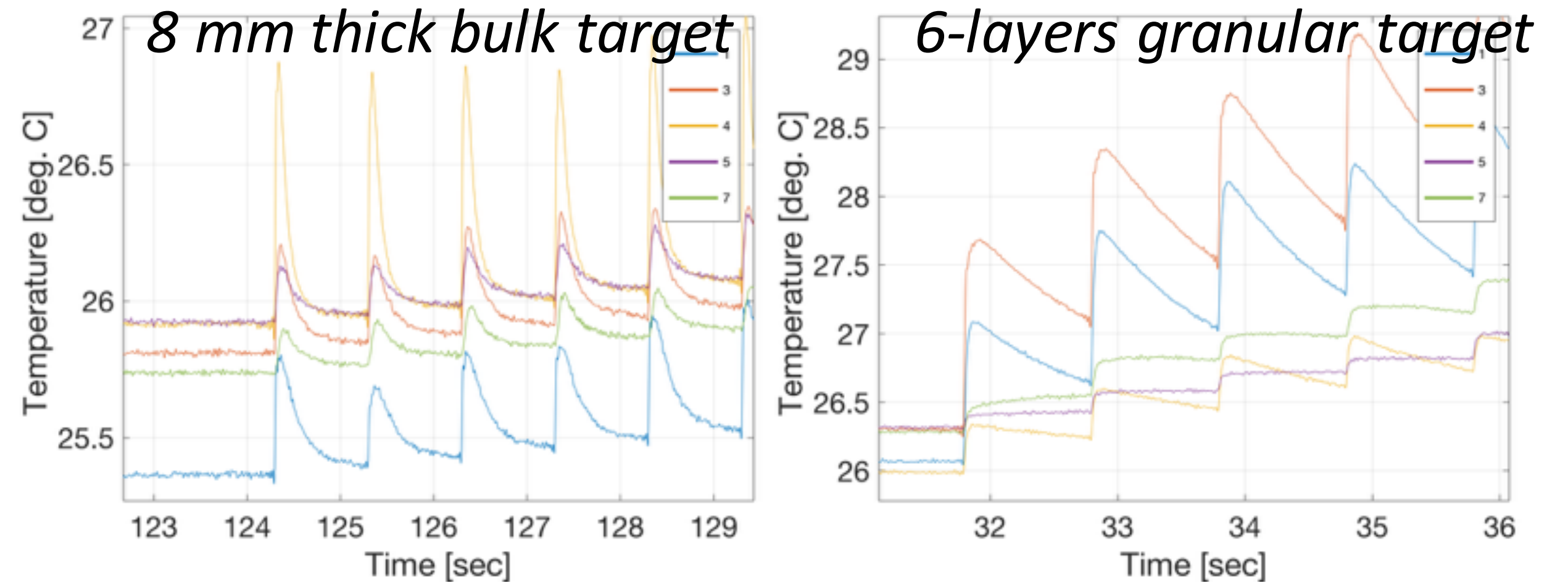
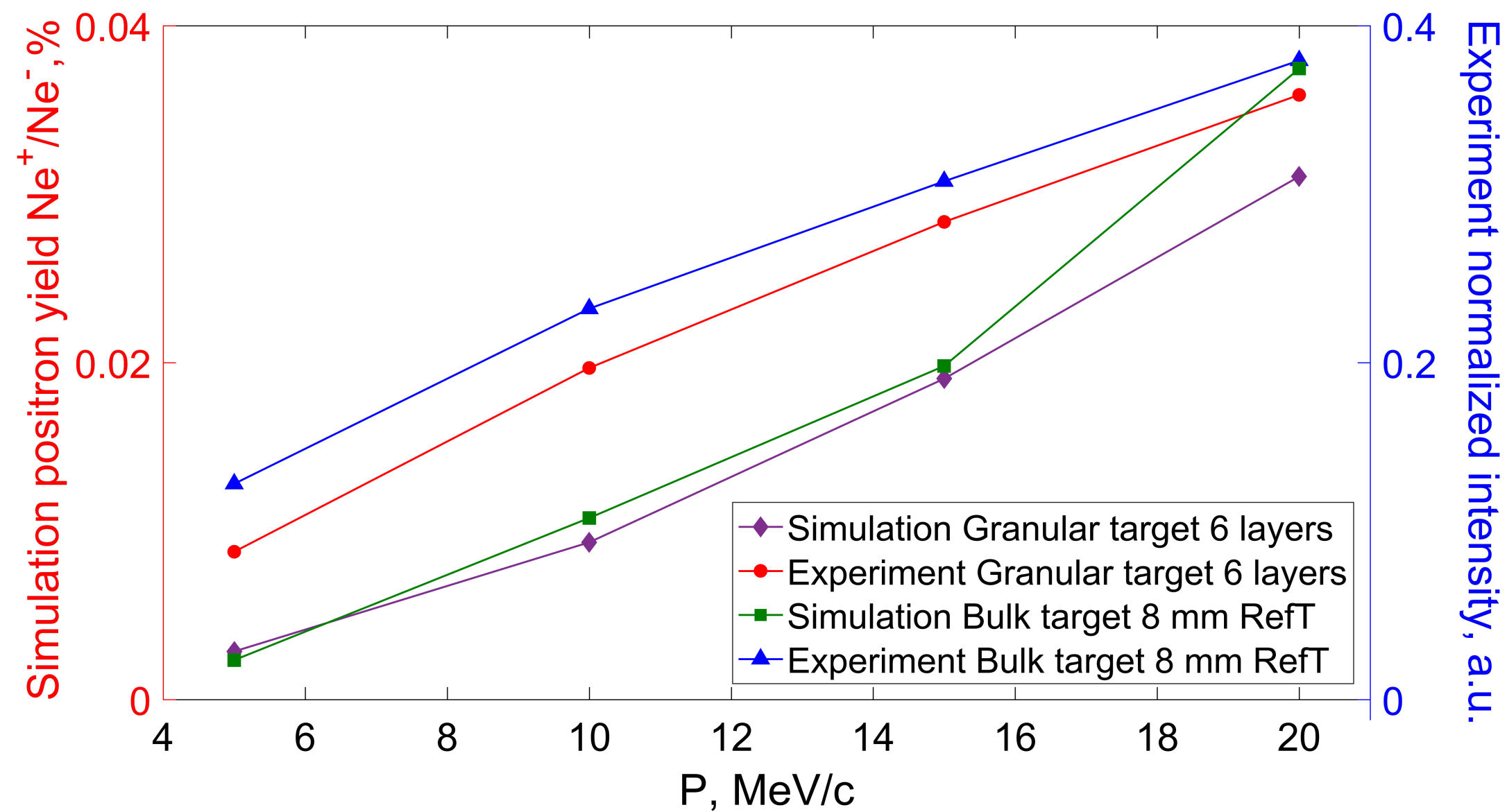

**Positron yield:** once the crystal axis was aligned with the e- beam, e+ yield was measured systematically for various conditions in hybrid and conventional schemes.

*The studies are ongoing*

**Temperature measurements:** it was performed in order to estimate the heat load in the bulk and granular converters.

Bunch-by-bunch temperature rise => PEDD information.

Temperature at equilibrium => total energy deposition.



# CLIC Positron Source

Separate injector complex to produce positron beam

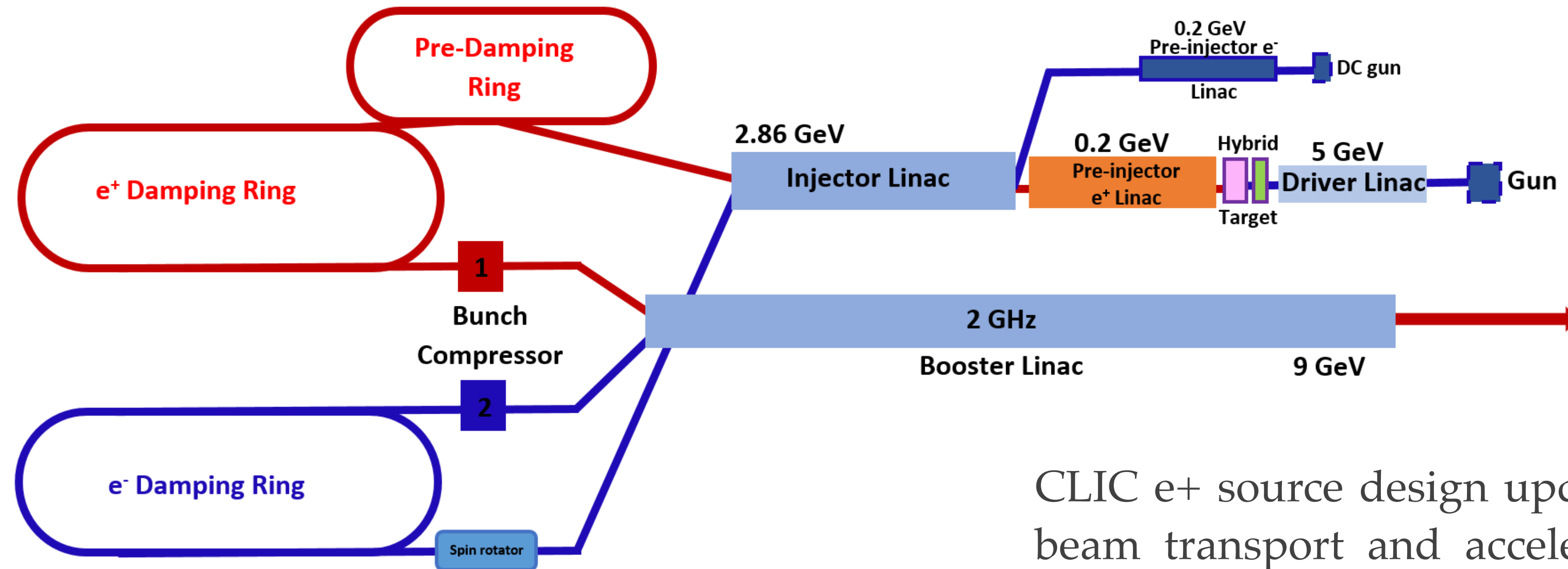

- **Electron Driver:** 5 GeV beam, NC L-band TW 352 bunches/pulse, 1 nC
- **e+ target:** 1.5 mm crystal + 3.7X0 (1.3 cm) thickness, (avg power dep ~ 10 kW, PEDD ~25 J/g)
- **Capture:** Flux Concentrator Bmax = 3 T
- **e+ polarization:** No

CLIC e+ source design update (compared to CDR): target layout, new beam transport and acceleration design from the target to the pre-damping ring => final e+ yield ~1.7 e+/e-, PEDD = ~25 J/g.

Hybrid scheme (CLIC CDR)

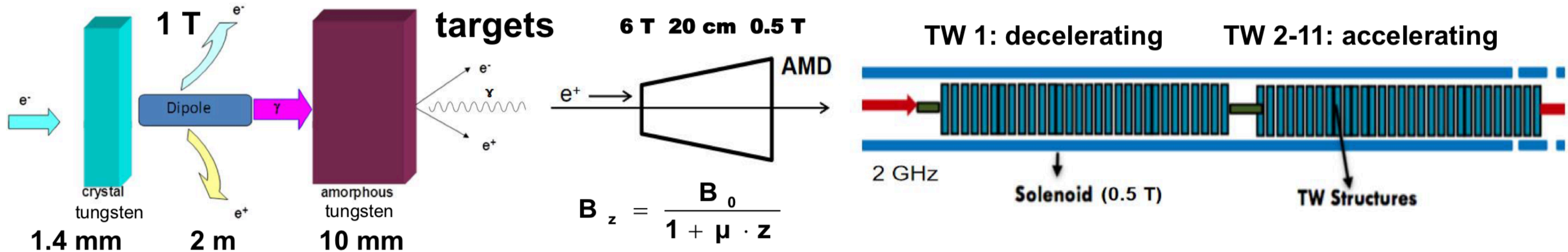



# FCC-ee positron source

**Dogleg**

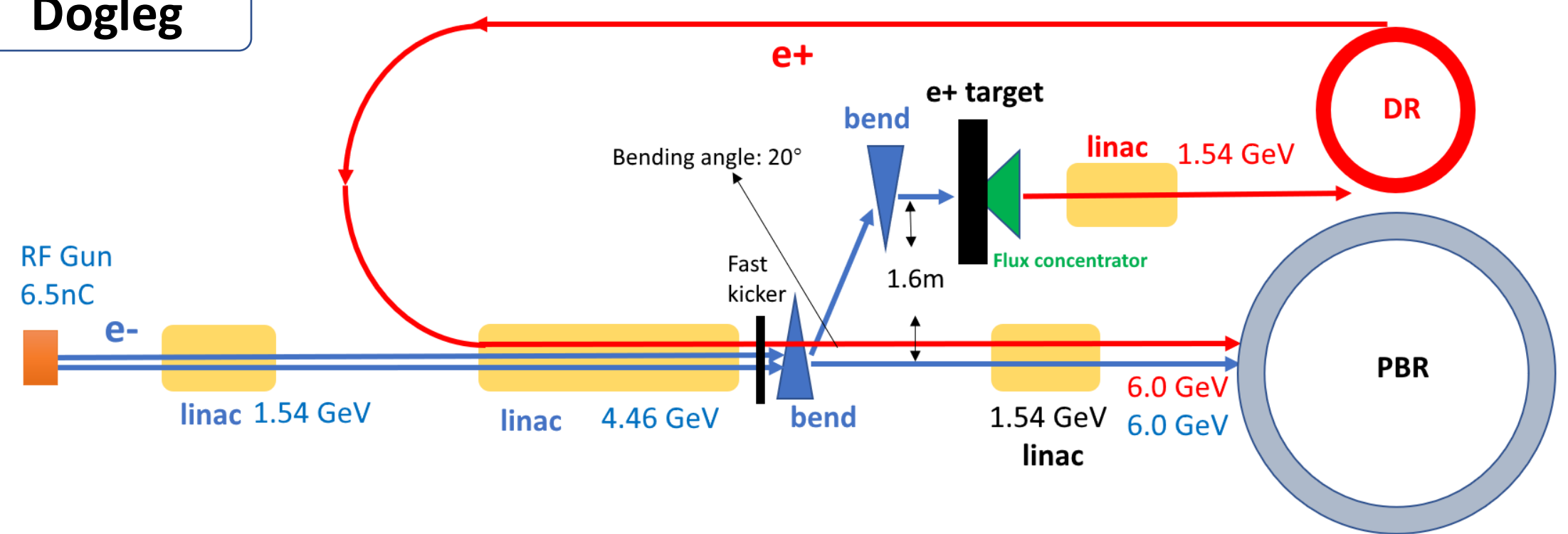

**Chicane**

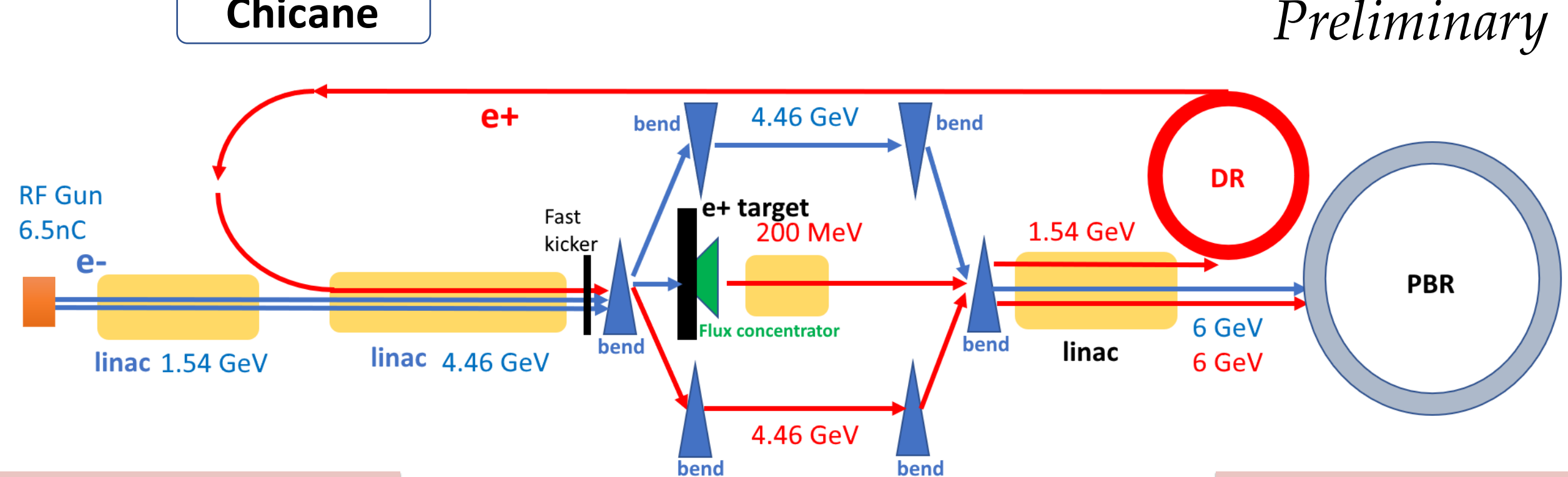

*Preliminary*

Primary e- beam for e+ production	
Beam energy	4.46 GeV
Bunch charge	$4.2 \times 10^{10}$
Bunch length (rms)	1 mm
Bunch transv. size (rms)	0.5 mm
Bunch separation	60 ns
Nb of bunches per pulse	2
Repetition rate	100-200 Hz
Beam power	12 kW

**Conventional scheme**

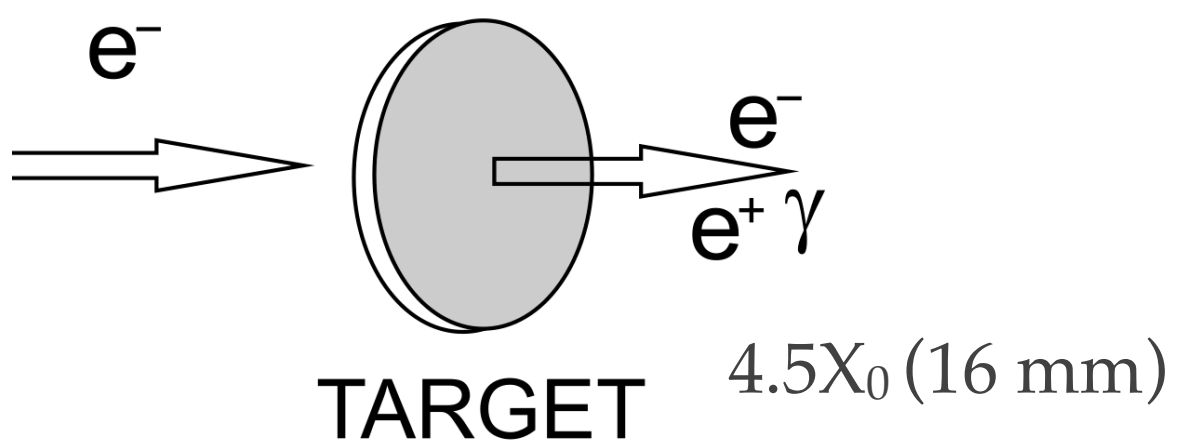

**Hybrid scheme**

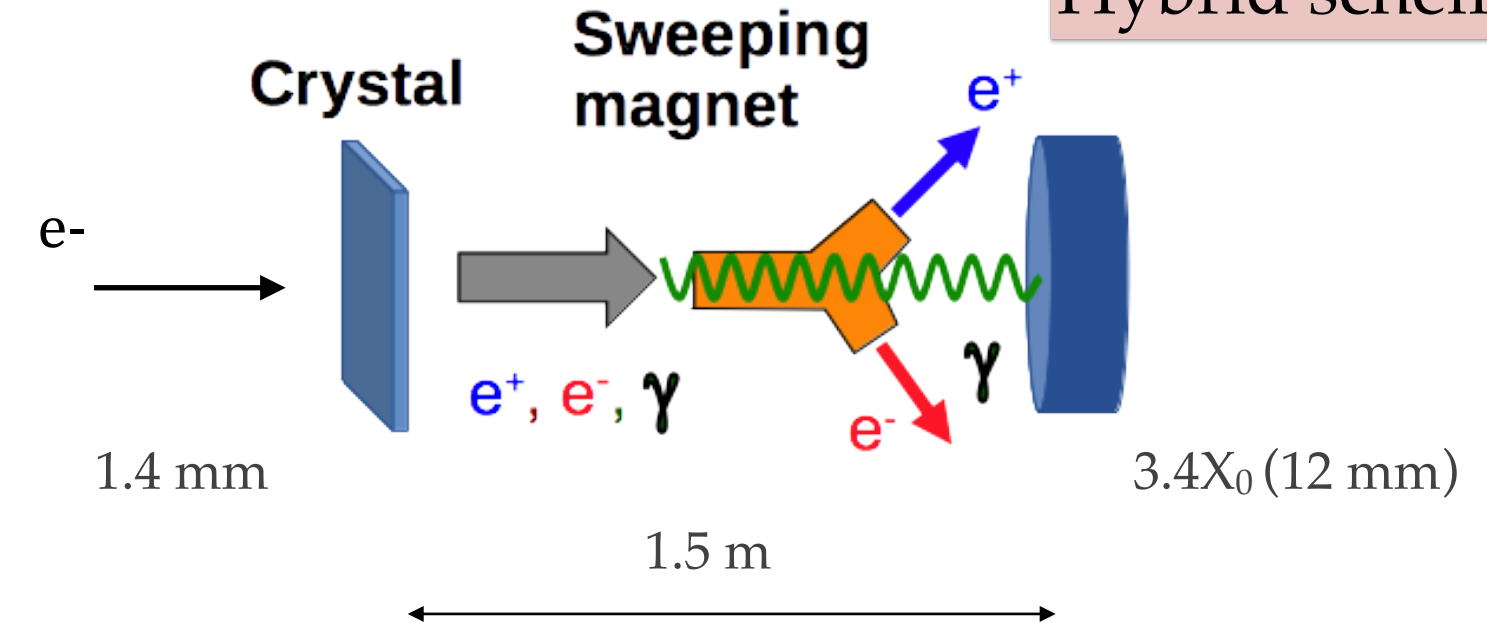

The final choice of the e+ target will be made based on the estimated performances.

The complete filling for Z running (most demanding) =>  
Requirement @ DR:  $\sim 2.1 \times 10^{10}$  e+ / bunch (4.3 nC)  
 **$\sim 0.5$  e+/e- without safety factor**

\*Alternative option: 20 GeV linac as the FCC-ee injector => higher energy for e+ production

# LEMMA: positrons for muons

## ☞ Positron-driven scheme: Low EMittance Muon Accelerator (LEMMA)

**Goal:** low emittance muon beams from direct pair production.  
 $e^+e^- \rightarrow \mu^+\mu^-$  Max efficiency  $\sim 10^{-5}$ .

Muons produced at  $\sqrt{s}$  around the  $\mu^+\mu^-$  threshold ( $\sqrt{s} \approx 0.212\text{GeV}$ ) in asymmetric collisions (corresponds to about 45 GeV  $e^+$  beam interacting with target).

Initial injection: the  $e^+$  source has to provide trains of **1000 bunches** with  $5 \times 10^{11}$   $e^+$ /bunch to inject in the DR at 5 GeV.

But the  $e^+$  source needed to replace the  $e^+$  lost in the muon production process is a real challenge (very short time available  $\sim 50$  ms).

=> Flux of  $10^{15} - 10^{16}$   $e^+$ /s is needed (experience from ILC/CLIC + R&D program on new targets).

